

Expert Transient

NEW!



Transient Data Acquisition
Stand alone. Compact. Powerful.



Expert Transient – Data recorder | Fault

Synchronous and fast

Expert Transient is a data recorder that can operate independently for the synchronous acquisition of transient and periodical processes. Measurement data can be triggered or continuously recorded over long time periods. Expert Transient is equipped with the powerful FPGA technology and provides the following features:

- Acquisition of transient and periodic signals
- Triggered and continuous acquisition modes
- Diverse range of analysis functions
- Includes the ProfiSignal Go analysis software
- Synchronously extendible with analog and digital inputs
- Independent, stand alone operation with long-term data storage capability
- Connectivity via Wi-Fi or UMTS / LTE networks
- Highly compact design
- Price advantage



Expert Transient is delivered with ProfiSignal Go software which enables recorded signals to be portrayed live in y(t) diagrams. Even large volumes of historical data are easy to analyse using the ProfiSignal software.

Expert Transient is equipped with 8 or 16 synchronous analog inputs and 4 digital inputs. The system can be extended to over 100 analog signals via a LAN interface with high-speed synchronization protocols. An extension for additional synchronous digital inputs is also possible.

Expert Transient

Inputs / outputs	Type 8	Type 16
Analog inputs (mV, mA)	8	16
Analog outputs (mV, mA)	4	4
Digital / frequency inputs	4	4
Digital outputs	8	8

Expert Transient inputs / outputs

Applications

- High-speed acquisition of analog or digital signals
- Fault diagnostics on machines, systems and test stands
- Evaluation of pressure pulses / surges
- High-speed process monitoring and controller optimisation
- Crash, detonation and explosion experiments
- Shock and vibration measurement
- Materials research and environmental simulation
- Test stands and lab experiments

t diagnostics | Transient data acquisition

Evaluation using ProfiSignalGo

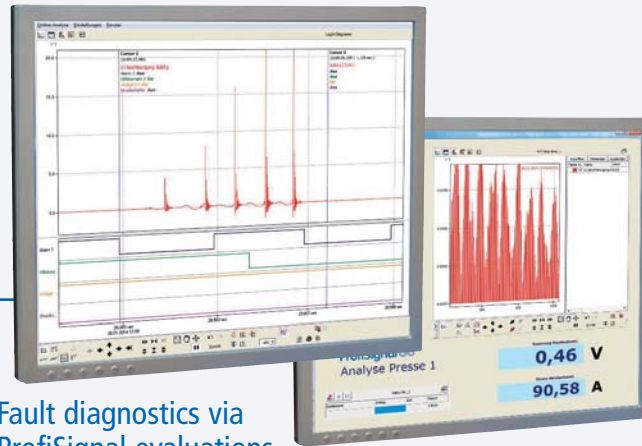

Fault diagnostics via ProfiSignal evaluations

Acquisition via Expert Transient

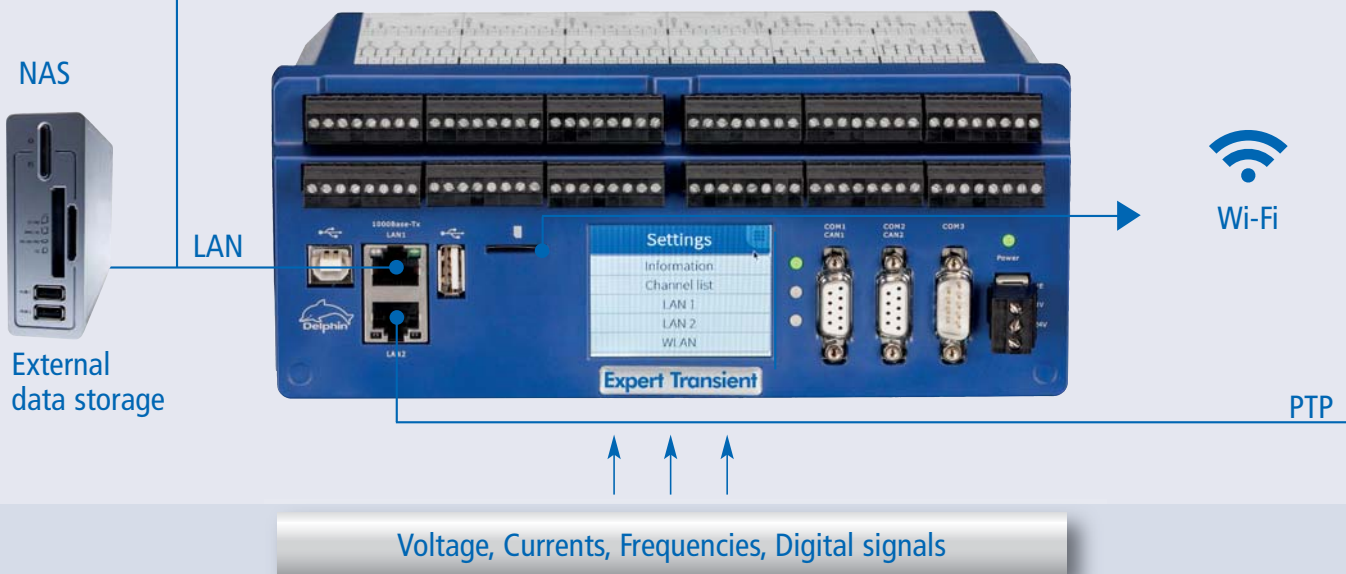

Field and system measurements



Input signals

- Acquisition and analysis of high-speed, transient signals
- Triggered or continuous recording modes
- Synchronous acquisition of 8 or 16 galvanically isolated, analog signals
- Sampling rates of up to 50 kHz per channel
- High measurement precision (24-bit ADC)
- Four synchronous digital inputs

Trigger and monitoring functions

- User-defined, multiple, flexible trigger events
- User-define data storage partitions and triggers
- High-speed digital outputs for limit value violations
- Alarms via email or text message
- Suitable for the acquisition of periodic signals (option to calculate FFT and characteristic values)

Signal conditioning

- Online computation of effective and peak values
- Upper wave analysis
- Online FFT analysis



mV, V, mA, A, DI, FI

Accessories

- NAS storage device with connectivity via LAN
- Mobile measurement case with BNC connectors
- Wi-Fi interface
- UMTS or LTE interface
- Tablet for evaluating measurement data

Interfaces and design

- Measurement and device configuration via LAN / Wi-Fi
- Remote connectivity via Wi-Fi, UMTS or LTE
- Standard device includes ProfiSignal Go software
- Highly compact design

Data recording

- Independent, internal 16 GB data storage capability
- Long-term data recording to NAS or SCSI drives
- Absolute-time synchronisation via GPS or NTP
- Automated FTP upload
- Internal time synchronisation via PTP



Extendible

- Over 100 synchronous analog channels
- Parallel acquisition of up to 100 digital channels
- Measurement data from slow processes

ProfiSignal Go – Included

Online and offline analysis

By using ProfiSignal Go, you can portray and analyse online and offline measurement data from Expert Transient devices. Only a few steps are required to go from configuring measurement channels to portraying trends. The portrayal of online and offline measurement data is virtually limitless. In online mode, users can zoom in on historical data with no interruption in the data being displayed. ProfiSignal Go is capable of processing both large and small data volumes. Detailed data are legible even at the highest zoom levels. Peaks are retained even when viewing across broad time ranges.

A range of evaluation options

ProfiSignal Go offers data portrayal as $y(t)$ diagrams, $y(x)$ diagrams, oscilloscope diagrams and digital logical analyses. All diagrams can be used and reused simultaneously. A patented storage algorithm enables the portrayal of measurement data from over several days, hours or μ -seconds. Searching for maximum and minimum values is thereby made simple.

Long-term archiving

ProfiSignal Go includes the full DataService software. This software offers functions for easy data storage and archiving. Measurement data can be archived to either a measurement data file or a database. ProfiSignal Go enables data to be exported in ASCII, CSV or Diadem™ formats.



Product features

- Monitoring and analysis of measurement data
- Recording to separate files
- Continuous recording to databases
- Online portrayal in trends
- Uninterrupted switching to offline data
- CSV / Diadem™ data export
- Output or export as EMF files
- Statistical evaluation
- Analysis using cursor functions down to μ -seconds
- Saving of diagram configurations
- Evaluation of digital signal processing

Expert Transient – Techn. specifications

Expert Transient

Inputs / outputs	
Analog inputs	8 or 16
Sampling rate, set per channel	1 Hz ... 50.000 Hz
Voltage / current ranges	± 25 V / 0 ... 20 mA, 4 ... 20 mA, free
Signal conditioning, software switchable	None, AC-coupling, IEPE
Resolution / input impedance	24 Bit / 4 M Ω
Dielectric withstand voltage / galvanic isolation	± 100 VDC / ± 400 VDC
Channel to channel	
Effective signal band width	DC ... 20 kHz
Digital frequency inputs	4
Input signal	low: 0 ... 2 V / high: 5 ... 50 VDC@3,5 mA / galvanically isolated
Measurement range, frequency inputs	0,2 Hz ... 1 MHz
Analog outputs	4
Resolution	16 Bit
Output range	0 ... 10 V / ± 10 V / 0 ... 20 mA / 4 ... 20 mA / galvanically isolated
Minimum / Maximum load resistance	500 Ω
Digital outputs	8
Switching voltage / switching current / PWM	50 V / 0,6 A / galvanically isolated / 5 Hz ... 10 KHz, to 1:500
Data storage	
Maximum size / measurement values	32 GB (approx. 2,300 million measured values)
Signal processing functions	
High pass / low pass / bandpass filters	
Cut-off frequency / filter ordering / filter characteristics	0,5 ... 20,000 Hz / 4, 6, 8, 10 / Bessel, and others
FFT	
Line number / window function / averaging	max. 12,800 lines / Hanning, Flat-Top ... / 2 ... 32-times
FFT types	Narrow band / wide band, envelope / demodulation, amplitude / phase spectra
Characteristic values from time signals	
Maximum / Minimum values, peak to peak values, arithmetical average, TRMS, RMS of product	
Characteristic values from a frequency spectra	
Frequency, main oscillation phase, any harmonic amplitude, frequency, total value, quadratic mean (in any frequency band), total or residual value	
Interfaces	
Physical equipment COM 1 / COM 2	RS485, 9-pole Sub-D connectors, DIN EN ISO 19245-1
Physical equipment COM 3	RS232, 9-pole Sub-D connector
LAN	1 x 1000Base-TX / 1 x 100Base-T
Wi-Fi / WWAN	802.11b/g/n / GPRS, UMTS, LTE
USB	Device 2.0 / Host 2.0
PROFIBUS	2 x PROFIBUS DPV1 / Slave max. 12 Mbit
CAN / RS 232/485	2 x CAN 2.0 / Modbus RTU, SCPI, ASCII
General technical information	
Dimensions / weight	210 mm x 80 mm x 125 mm / 750 g
Fixing	DIN EN 60715 rail or screw fixing, plug-in screw terminals, 96 terminals in 2 rows
Signal connections	max. 1,5 mm ²
Temperature range	-20 ... 60 °C
Power supply / power input	12 ... 24 VDC / $\pm 10\%$ / ca. 20 Watts

Delphin Technology AG
Lustheide 81
51427 Bergisch Gladbach · Germany

Phone +49 (0) 2204 97685-0
Fax +49 (0) 2204 97685-85
info@delphin.de · www.delphin.com

