



RHT-XS Transmitter

USER GUIDE – V3.0x



NOVUS
We Measure, We Control, We Record



1.	SAFETY ALERTS.....	3
2.	INTRODUCTION.....	4
3.	INSTALLATION.....	4
3.1	MECHANICAL INSTALLATION.....	4
3.2	TYPES OF TIPS.....	4
3.2.1	INSTALLATION.....	4
3.3	ELECTRICAL INSTALLATION.....	5
3.3.1	4-20 MA MODEL.....	5
3.3.2	0-10 VDC MODEL.....	5
3.3.3	INSTALLATION RECOMMENDATIONS.....	5
3.3.4	PRECAUTIONS WHEN HANDLING SENSORS.....	5
3.3.5	SENSOR REPLACEMENT.....	6
4.	CONFIGURATION.....	7
5.	SIGNOW SOFTWARE AND APP.....	8
5.1	SIGNOW SOFTWARE.....	8
5.1.1	CONFIGURATION SECTION.....	8
5.1.2	DIAGNOSTIC SECTION.....	10
5.2	SIGNOW APP.....	12
6.	SPECIFICATIONS.....	13
6.1	ACCURACY OF MEASUREMENTS AND OPERATING LIMITS OF SENSORS.....	14
6.2	CERTIFICATIONS.....	14
7.	WARRANTY.....	15

1. SAFETY ALERTS

The following symbols are used on the equipment and throughout this manual to draw the user's attention to important information related to the safety and use of the equipment.

		
CAUTION Read the manual completely before installing and operating the device.	CAUTION OR HAZARD Risk of electric shock.	ATTENTION Material sensitive to static charge. Be sure to take proper precautions before handling it.

All safety recommendations appearing in this manual must be followed to ensure personal safety and prevent damage to the instrument or system. If the instrument is used in a manner other than that specified in this manual, the device safety protections may not be effective.

2. INTRODUCTION

RHT-XS transmitter features a highly accurate and stable sensor for measuring relative humidity and temperature. The measured values are converted into 4 to 20 mA output signals linearly related to their readings. Optionally, the outputs can be offered in 0 to 10 Vdc voltage.

Since they are microprocessor-based devices, they can be configured via **SigNow** software or app. Humidity measurement and transmission can be configured between **Relative Humidity** and **Dew Point**.

3. INSTALLATION

3.1 MECHANICAL INSTALLATION

The electronic module of RHT-XS must be fixed to the wall. The remote sensor module allows you to monitor environments where the electronic module cannot operate.

By removing the cover of the transmitter electronic module, you have access to the two fixing holes, as shown in the figure below:

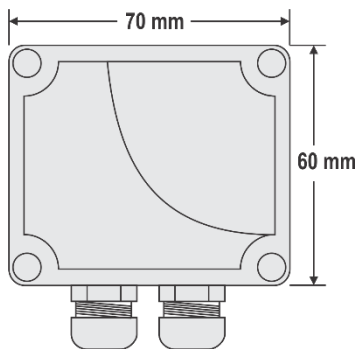

Figure 1 – Electronic module dimensions

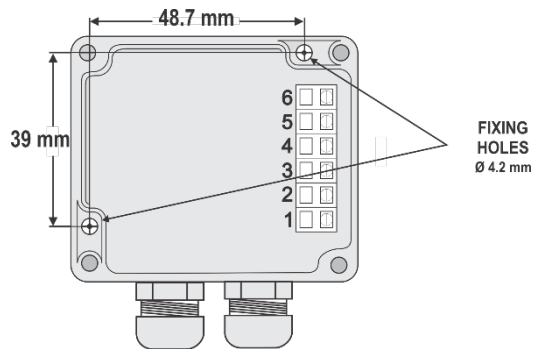

Figure 2 – Fixing holes

The figure below shows the dimensions of the remote sensor module:

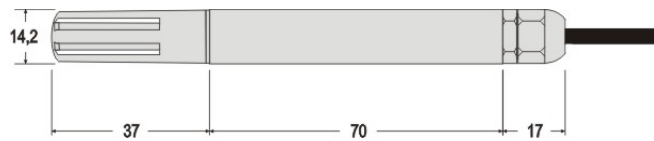

Figure 3 – Remote sensor module dimensions (mm)

3.2 TYPES OF TIPS

NOVUS offers 3 types of tips, which can be purchased from authorized distributors:

- **Polyamide tip** (see figure beside): It has side openings that allow the sensor to be more exposed to the environment in which it was installed, having a shorter response time. This tip comes with RHT.
Order code: 8803900120
- **High Density Polyethylene (PE) tip** (see figure beside): Made of a porous material, it protects the sensor from dust and other solid particles. However, by reducing contact with the environment to be measured, the response time of this tip tends to be longer than that of the Polyamide tip (see **Note 1**).
Order code: 8803900110
- **Sintered Bronze Tip** (see figure beside): Made of a porous material, it protects the sensor from dust and other solid particles. It has more mechanical robustness than the Polyethylene tip. However, by reducing contact with the environment to be measured, the response time of this tip tends to be longer (see **Note 1**).
Order code: 8803900100



Note 1: This increase in response time depends, among other things, on the speed of the air (or gas) where the sensor is inserted.

3.2.1 INSTALLATION

1. Remove the tip from RHT by slowly unscrewing it. When removing it, take care that only the tip rotates in the equipment.
2. The sensor circuit board will be exposed. It must not be touched!
3. Screw in the new tip carefully. It is not necessary to force the thread at the end.

3.3 ELECTRICAL INSTALLATION

3.3.1 4-20 mA MODEL

The figures below show the electrical connections of the 4-20 mA model:

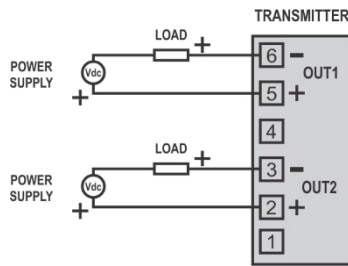

Figure 4 – Connections

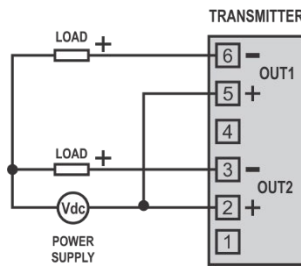

Figure 5 – One power supply

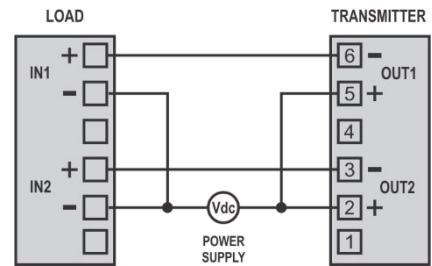
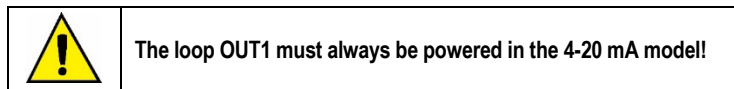

Figure 6 – One power supply and load with two input channels

In the figures above, **LOAD** represents the measuring instrument of the output signal (indicator, controller, register, etc.).

The connection wires go inside the transmitter trough to the cable gland mounted in the transmitter housing.



3.3.2 0-10 Vdc MODEL

The figure below shows the electrical connections of the 0-10 Vdc model:

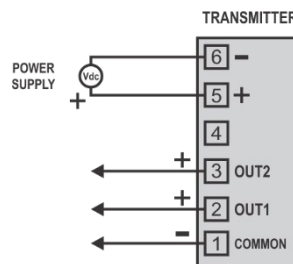

Figure 7 – 0-10 Vdc connections

In the figure above, **LOAD** represents the measuring instrument of the output signal (indicator, controller, register, etc.).

The connection wires go inside the transmitter trough to the cable gland mounted in the transmitter housing.

3.3.3 INSTALLATION RECOMMENDATIONS

- Conductors of small electric signals must be separated from activation conductors or higher current or power in the system plan. If possible, in grounded conduits.
- The instrument supply must come from a network proper for instrumentation.
- In control and monitoring applications, it is essential to consider what may happen when any part of the system fails.
- It is recommended to use RC FILTERS (47 Ω and 100 nF, series) in parallel with coils of contactors and solenoids, etc.

3.3.4 PRECAUTIONS WHEN HANDLING SENSORS

If exposed to contaminant vapors or extreme humidity and temperature conditions for prolonged periods, the calibration of the humidity sensor may be affected. To accelerate the calibration reset, proceed as described below:

- Remove the sensor from the capsule.
- If solid particles are deposited on the sensor, rinse it with deionized water.
- Place the sensor in an oven between 80 and 90 °C and humidity less than 5% RH for 24 hours.
- For 48 hours, place the sensor in a location with a temperature between 20 and 30 °C and humidity greater than 75 % RH.
- Replace the sensor in the capsule.

3.3.5 SENSOR REPLACEMENT

Em In case of damage, it may be necessary to replace the sensor. To perform this procedure, follow the steps below:



- **Step 1:** Disconnect the equipment from the power supply. Locate the protective tip of the sensor.

This example displays the replacement of the sensor of a RHT transmitter. In it, the sensor is located at the end of the probe.

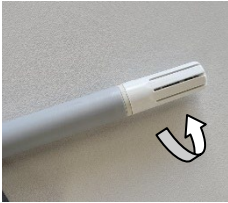

- **Step 2:** Remove the tip by turning it counterclockwise.

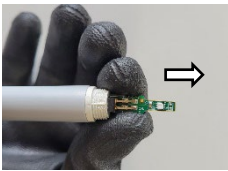

- **Step 3:** Without the tip, the sensor will be exposed. It should be removed by pulling it forward to disconnect it.

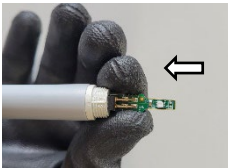

- **Step 4:** Connect the new sensor to the probe tip connector. Use clean anti-static gloves or other measures to prevent static discharge. Avoid unnecessary handling.

	 <p>The sensor should only be held by the connector area and its proximities. Avoid handling the sensor by the thinner end. Do not touch the sensor.</p> <p>For this procedure, it is recommended to wear clean anti-static gloves.</p>
---	---



- **Step 5:** Replace the protective tip and slowly turn it clockwise to secure it to the equipment.

4. CONFIGURATION

For the model already configured with the proper ranges, no intervention is required. The installation can be performed immediately.

When you need to change the configuration, you should use **SigNow** software or app (see [SIGNOW SOFTWARE AND APP](#) chapter).

To configure the equipment through the software, you must connect the **TxConfig-USB** Configuration Interface (purchased from the manufacturer or its authorized representatives) to the USB port of the computer used and run the software, as shown in the figure below:

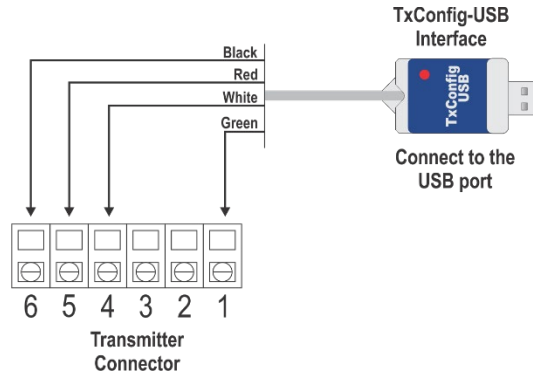

Figure 8 – TxConfig-USB Interface Connections

To configure the device via **SigNow** app, you need to use an OTG cable with the **TxConfig-USB** Configuration Interface. Smartphones with On the Go (OTG) technology can be directly connected to the device via the USB port. Using the **TxConfig-USB** Configuration Interface, it is possible to recognize and configure **RHT** by running **SigNow** app.

To do this, as shown in the figure below, you need to observe how to connect the OTG cable to the equipment:

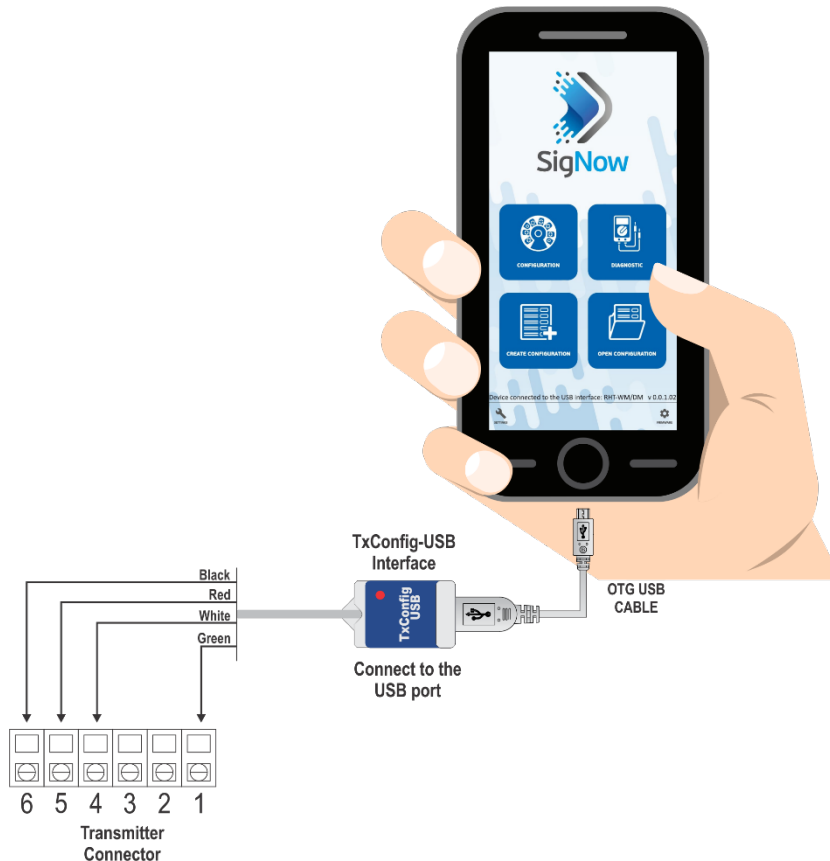

Figure 9 – OTG Cable



If you position the cable end incorrectly, it is possible that the device will not be recognized by the application.

On **NOVUS** website, you can download the configuration software for free (see [SIGNOW SOFTWARE](#) section).

SigNow app can be downloaded for free from *Google Play Store* (see [SIGNOW APP](#) section).

5. SIGNOW SOFTWARE AND APP

The **SigNow** software and app are the main tools for configuring and analyzing **RHT** data. They allow you to explore all the features of the equipment, communicating through the **TxConfig-USB** Configuration Interface.

This manual describes the features related to **RHT**. For more specific instructions on how to operate **SigNow** tools, check the specific operations manual. The software and its respective manual can be downloaded for free in the Download Area of our website www.novusautomation.com.

To install it, simply run the **SigNowSetup.exe** file and follow the instructions in the installer.

SigNow app can be downloaded for free from *Google Play Store*.

5.1 SIGNOW SOFTWARE

When running **SigNow**, the home screen will be presented:



Figure 10 – Home screen

To communicate with the software, **RHT** must be connected to the computer through a **TxConfig-USB** Configuration Interface and have the USB drivers previously installed (see [CONFIGURATION](#) chapter).

Next, click on **Configuration** (see [CONFIGURATION SECTION](#)) or **Diagnostic** (see [DIAGNOSTIC SECTION](#)).

5.1.1 CONFIGURATION SECTION

The **Configuration** button, located on **SigNow** home screen, reads the current configuration of the device. Selecting this option will display all the features available for configuration, as shown in the sections below.

The configuration screen is divided into 4 sections: **Temperature**, **Humidity**, **Output 1**, and **Output 2**. The bottom part of the screen displays information about the equipment, such as name, serial number, and firmware version.

5.1.1.1 TEMPERATURE CONFIGURATION

When connecting to the equipment, the following screen will be displayed:

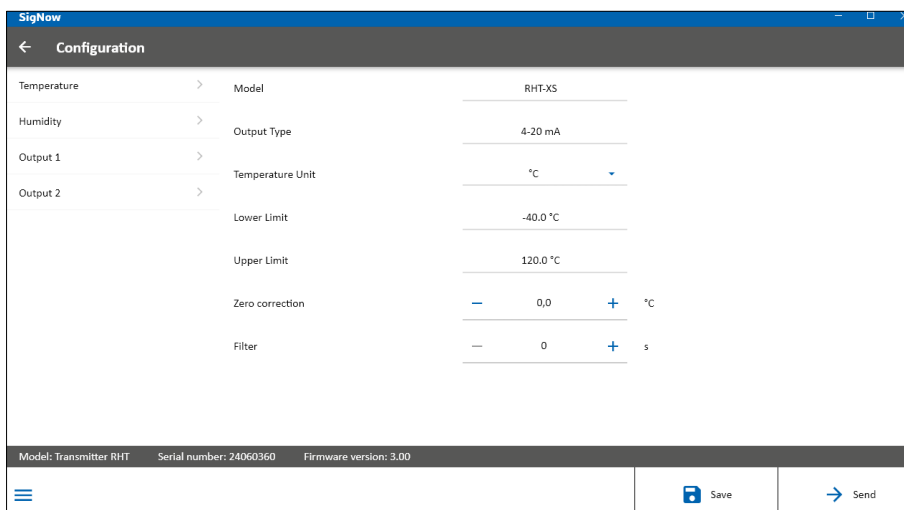

Figure 11 – Temperature configuration

In the **Temperature** screen (see above), you can see information and set values for the following parameters:

1. **Model:** Shows the RHT model.
2. **Output type:** Shows the output type of the equipment.
3. **Temperature Unit:** Allows you to set the temperature unit to be used.
4. **Lower Limit:** Displays the minimum temperature for the output type.
5. **Upper Limit:** Displays the maximum temperature for the output type.
6. **Zero Correction:** Allows you to adjust the Offset of the reading of the measured quantity.
7. **Filter:** Allows you to set the filter value to be applied.

5.1.1.2 HUMIDITY CONFIGURATION

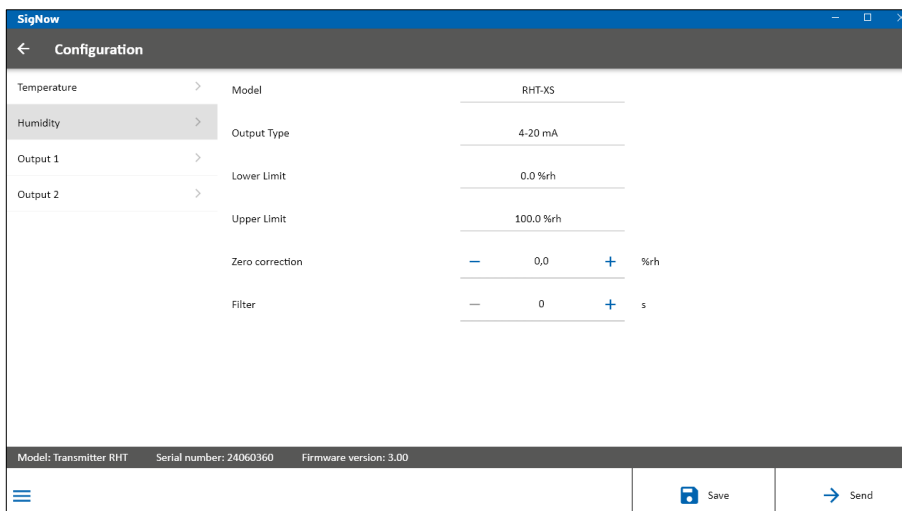

Figure 12 – Humidity configuration

In the **Humidity** screen (see above), you can see information and set values for the following parameters:

1. **Model:** Shows the RHT model.
2. **Output type:** Shows the output type of the equipment.
3. **Lower limit:** Displays the minimum relative humidity percentage for the output type.
4. **Upper limit:** Displays the maximum relative humidity percentage for the output type.
5. **Zero Correction:** Allows you to adjust the Offset of the reading of the measured quantity.
6. **Filter:** Allows you to set the filter value to be applied.

5.1.1.3 OUTPUT 1 CONFIGURATION

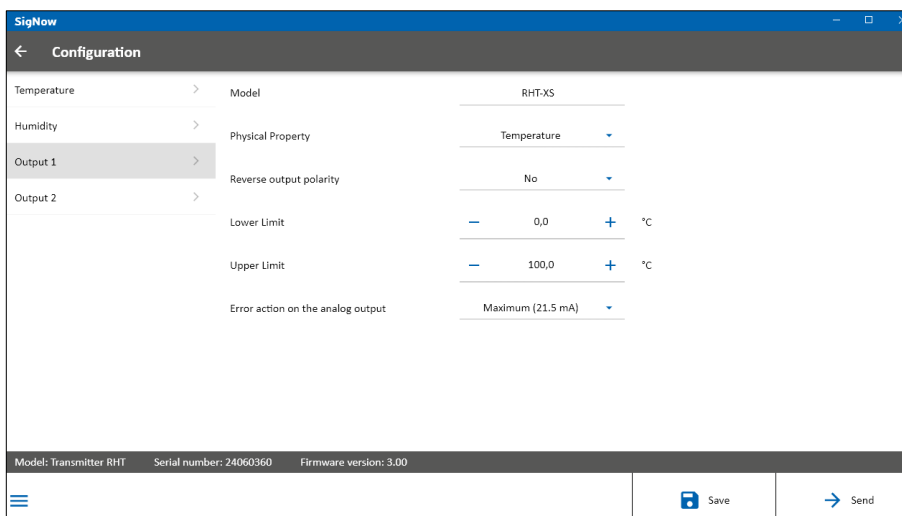

Figure 13 – Output 1 Configuration

In the **Output 1** (see above), you can see information and set values for the following parameters:

1. **Model:** Shows the RHT model.
2. **Physical property:** Allows you to set the physical property to be measured: **Temperature**, **Humidity**, or **Dew Point**. By clicking the **Off** option, it is possible to disable this output.
3. **Reverse output polarity:** Allows you to reverse the polarity of the output.
4. **Lower limit:** Allows you to set the desired minimum temperature for the output type.

5. **Upper limit:** Allows you to set the desired maximum temperature for the output type.
6. **Analog output error action:** If an error is detected in the analog output, it allows you to set the error action to be taken, either for maximum error or minimum error.

5.1.1.4 OUTPUT 2 CONFIGURATION

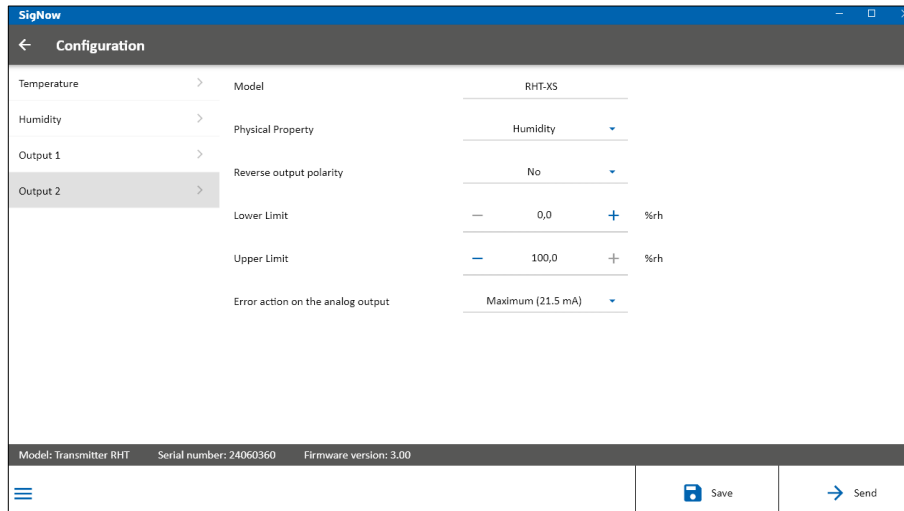

Figure 14 – Output 2 configuration

In the **Output 2** (see above), you can see information and set values for the following parameters:

1. **Model:** Shows the **RHT** model.
2. **Physical property:** Allows you to set the physical property to be measured: **Temperature, Humidity, or Dew Point**. By clicking the **Off** option, it is possible to disable this output.
3. **Reverse output polarity:** Allows you to reverse the polarity of the output.
4. **Lower limit:** Allows you to set the desired minimum relative humidity percentage for the configured output type.
5. **Upper limit:** Allows you to set the desired maximum relative humidity percentage for the configured output type.
6. **Analog output error action:** If an error is detected in the analog output, it allows you to set the error action to be taken, either for maximum error or minimum error.

5.1.2 DIAGNOSTIC SECTION

The **Diagnostic** button, located on **SigNow** home screen, allows you to obtain information about the operation of the equipment, as well as to force values according to the type of output. This example shows the current output, so it is possible to force values within the 4-20 mA range, maximum (21.5 mA) or minimum (3.6 mA) error values.

To use this feature, you need to use an external source. In addition, you must use a **TxConfig-USB** Configuration Interface to connect your **RHT** to the USB port of the computer.

Below is an example of the electrical connections:

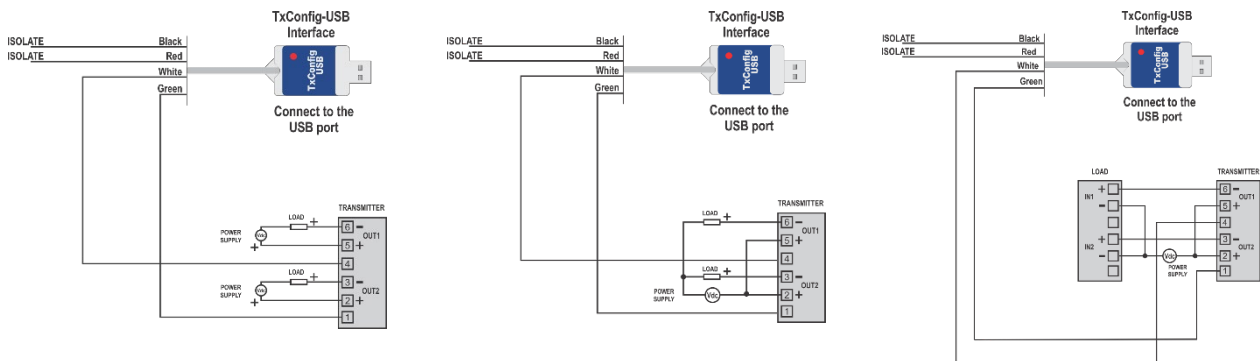

Figure 15 – Electrical connections of the example

Once you have made the necessary connections, simply access the **Diagnostic** section of the software. By selecting the **Output** option of the **Forcing** tab, it is possible to force values for outputs 1 and 2. In these examples, values are being measured using a multimeter:

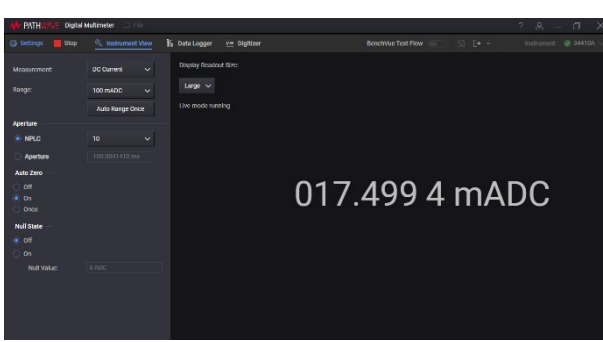

Figure 16 – Forcing values to output 1

At the bottom of the graph, there are checkboxes that allow you to enable or disable the display of information about the temperature, relative humidity, and Dew Point values: Relative Humidity: 60.7 %rh, Temperature: 22.9 °C and Dew Point: 14.6 °C.

The examples below show situations where you are forcing a minimum error value and then a maximum error value:

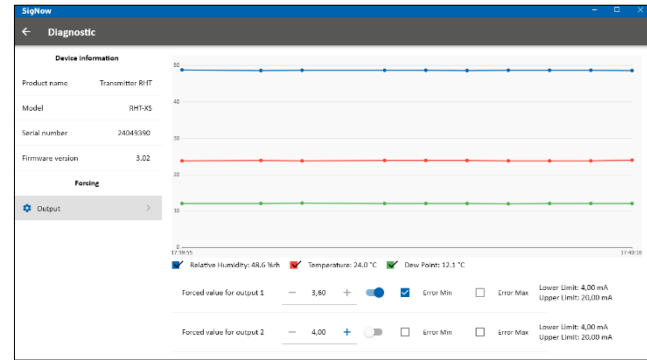
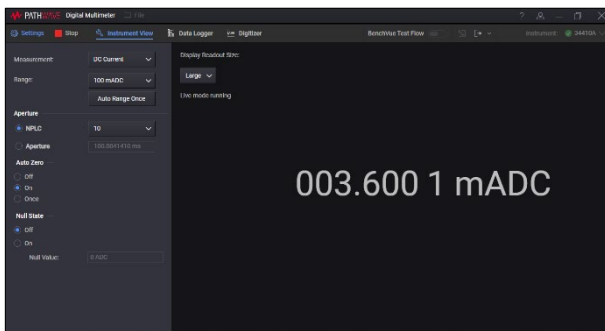

Figure 17 – Forcing minimum error values

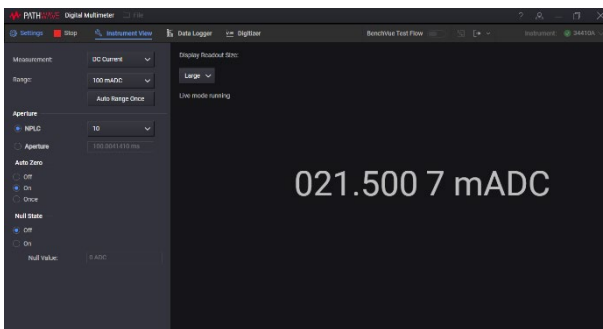

Figure 18 – Forcing maximum error values

5.2 SIGNOW APP

When using an OTG cable (not supplied) and the **TxConfig-USB** Configuration Interface to connect the equipment to your smartphone and run **SigNow** app (see [CONFIGURATION](#) chapter), you must first enable the use of **TxConfig-USB**. The interface will act as an intermediary for the connection:

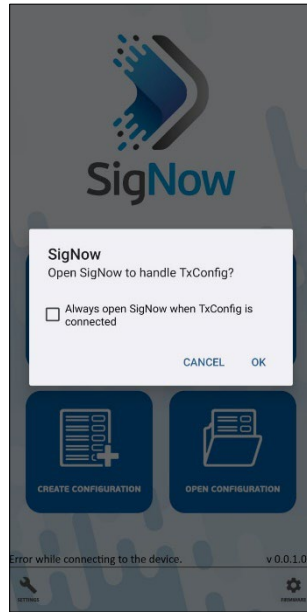

Figure 19 – Using TxConfig-USB

After that, the app will recognize the equipment and show the main screen:

Just click on the **Configuration** button to display the main screen of the **RHT** Configuration section:



Figure 20 – Main screen



Figure 21 – Information screen

This is the first screen of the section and displays information about the equipment.

Clicking on the **Config** button allows you to display the configuration sections.

This screen shows information about the equipment, such as name, serial number, and firmware version.

When you open the **Config** section, you can configure the parameters displayed in the [CONFIGURATION SECTION](#). By clicking on the **Diagnostic** button on the home screen, you can perform diagnostics and force values for the outputs (see [DIAGNOSTIC SECTION](#)).

To make the integration process more user-friendly, **SigNow** app and **SigNow** software have the same screens and the parameters of the respective screens are always the same.

In **SigNow** manual, available on **NOVUS** website, it is possible to obtain more information about some features, such as the firmware update process and the process of creating and saving a configuration.

6. SPECIFICATIONS

FEATURES	RHT-XS
Humidity measurement	<p>Total accuracy: See Figure 22.</p> <p>Measuring range: Configurable between 0 and 100 % RH or -100 and 103 °C (-148 and 217.4 °F) for dew point.</p> <p>Response time (1/e (63 %)): 8 seconds @ 25 °C (is slow moving air 1 m/s).</p>
Temperature measurement	<p>Total accuracy: See Figure 22.</p> <p>Total accuracy: Configurable between -40 and 120 °C (-40 and 248 °F).</p> <p>Response time (1/e (63 %)): up to 30 s (is slow moving air 1 m/s).</p>
Power supply	<p>4-20 mA model: 12 to 30 Vdc</p> <p>0-10 V model: 18 a 30 Vdc / 15 mA max.</p>
Sensor reading range	< 1.5 seconds
Outputs	<p>4-20 mA or 20-4 mA current, 2-wire loop power supply.</p> <p>0-10 Vdc tension / 2 mA max.</p>
Output Load (RL)	<p>4-20 mA model: RL (Ohms max.) = (Vdc - 12) / 0.02 let: Vdc = Power supply in Volts.</p> <p>0-10 Vdc model: 2 mA max.</p>
OUT1 and OUT2 outputs resolution	<p>4-20 mA model: 0.0008 mA.</p> <p>0-10 Vdc model: 0.003 V.</p>
Isolation between loops	The 4-20 mA outputs are isolated from each other. The 0-10 V outputs are not isolated from each other.
Protection	<p>Electronic circuit housing: IP65</p> <p>Sensor capsule: IP40</p>
Cable entrance	Compress fitting PG7.
Operating limits	Sensor (RHT-XS): See Figure 22.
Electronic circuit	<p>Electronic circuit (RHT-XS):</p> <p>Operating temperature: -20 to 70 °C (-4 to 158 °F), 0 to 95 % RH</p> <p>Storage temperature: -20 to 80 °C (-4 to 176 °F)</p>
Certifications	<p>CE Mark</p> <p>This is a Class A product. In a domestic environment, this product may cause radio interference in which case the user may be required to take adequate measures.</p>
Provides protection against power supply polarity inversion.	

Table 1 – Technical specifications

IMPORTANT

The sensor used in this equipment may be damaged or lose calibration if it is exposed to atmospheres contaminated with chemical agents. Hydrochloric Acid, Nitric Acid, Sulfuric Acid, and Ammonia in high concentrations can damage the sensor. Acetone, Ethanol and Propylene Glycol can cause reversible measurement error.

6.1 ACCURACY OF MEASUREMENTS AND OPERATING LIMITS OF SENSORS

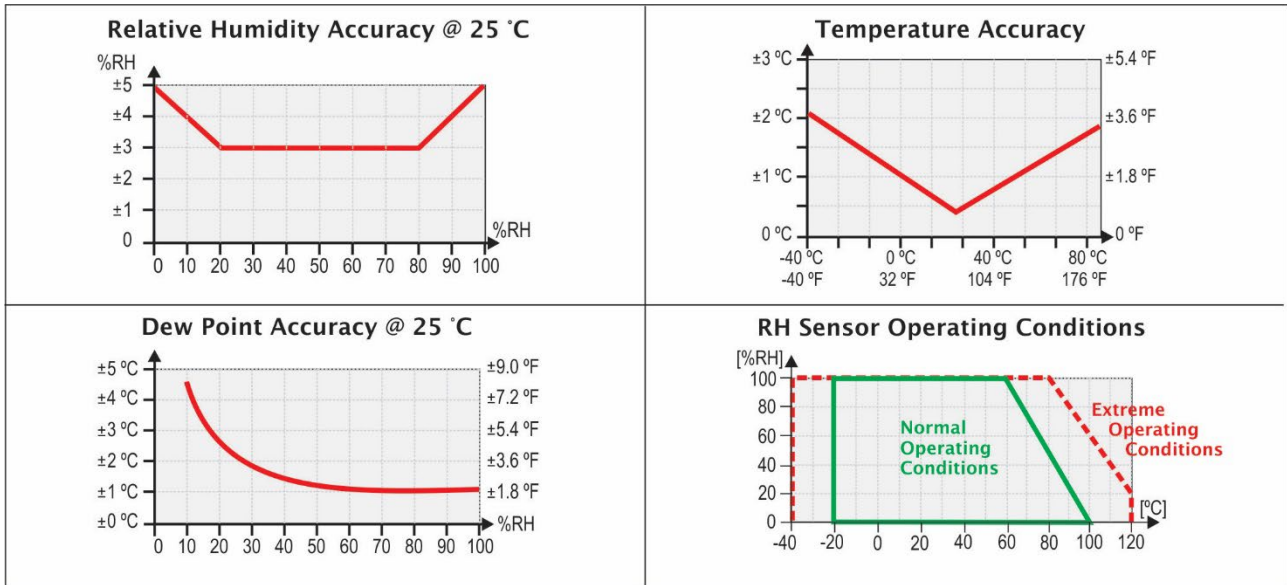

Figure 22 – Accuracy in measuring humidity and temperature

6.2 CERTIFICATIONS

CE Mark / UKCA

This is a Class A product. In a domestic environment, this product may cause radio interference in which case the user may be required to take adequate measures.

7. WARRANTY

Warranty conditions are available on our website www.novusautomation.com/warranty.