

K Box Pinouts (INF 2201)



K-Box instrumentation device

The CAN Connectors (2x DB9 CAN Connectors)

The CAN Connectors are 1x Male and 1x Female 9-pin Standard D Type Connectors with nuts.

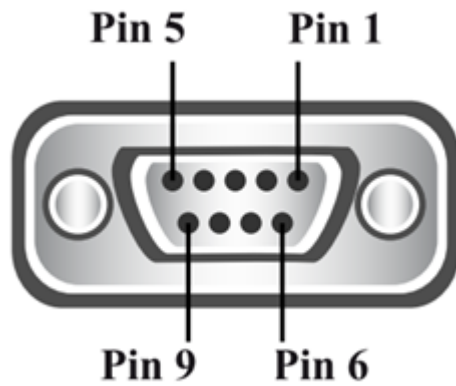

Female 9-pin Standard D-Type Connector

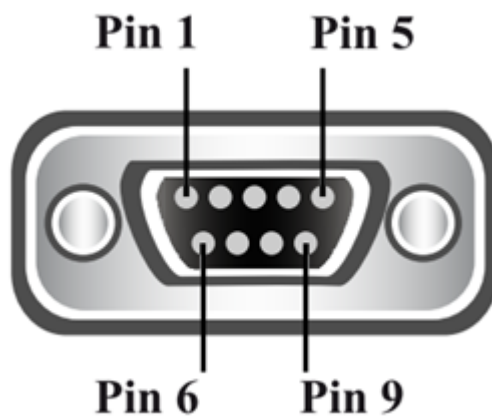

Male 9-pin Standard D Type Connector

Pin No	Pin Function
Pin 1	Digital Output 4 or +4.5V Instrumentation Supply Voltage, ensure that current draw is not more than 100mA
Pin 2	CAN Bus Low Signal
Pin 3	Ground
Pin 4	Digital Input or Output 1 - Do not apply voltages outside of the 0 to +12V range when used as an input. When used as an Output, ensure that the current drawn is not more than 100mA. More information on the use of this pin can be found in Appendix 2 and 3
Pin 5	Power Ground

Pin 6	Digital Input or Output 3
Pin 7	CAN Bus High Signal
Pin 8	Digital Input or Output 2 - Do not apply voltages outside of the 0 to +12V range when used as an input. When used as an Output, ensure that the current drawn is not more than 100mA. More information on the use of this pin can be found in Appendix 2 and 3
Pin 9	4.5-20V Supply Voltage

⚠ WARNING:

- Each End of the CAN bus must be terminated with a 120-ohm resistor across CAN H and CAN L.

The ADC Connector

The ADC Connector is a Male 25-pin Standard D-Type Connector with nuts.

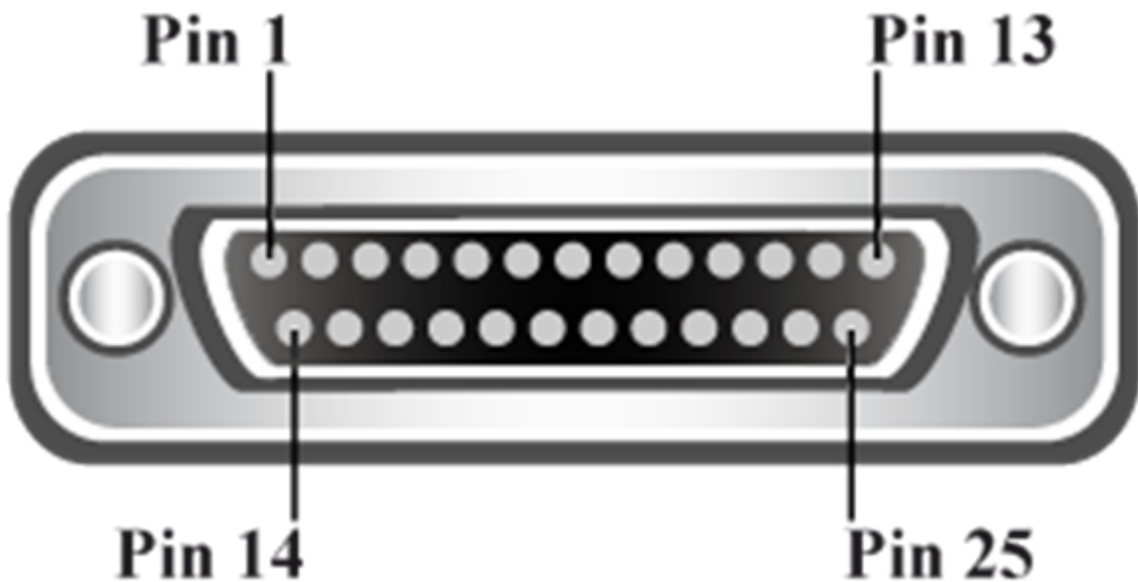

Male 25-pin Standard D-Type Connector

Pin No

Pin Function

Pin 1	+24V Output - ensure that the current drawn is not more than 75mA
Pin 2	+5V Output - ensure that the current drawn is not more than 75mA
Pin 5	Analog Ground
Pin 6	Analog Input 0 + ve (do not apply voltages outside the voltage range the K-Box is configured for).
Pin 7	Analog Input 1 + ve (do not apply voltages outside the voltage range the K-Box is configured for).
Pin 8	Analog Input 2 + ve (do not apply voltages outside the voltage range the K-Box is configured for).
Pin 9	Analog Input 3 + ve (do not apply voltages outside the voltage range the K-Box is configured for).
Pin 10	Analog Input 4 + ve (do not apply voltages outside the voltage range the K-Box is configured for).
Pin 11	Analog Input 5 + ve (do not apply voltages outside the voltage range the K-Box is configured for).
Pin 12	Analog Input 6 + ve (do not apply voltages outside the voltage range the K-Box is configured for).
Pin 13	Analog Input 7 + ve (do not apply voltages outside the voltage range the K-Box is configured for).
Pin 14	Ground Out
Pin 15	Ground Out
Pin 17	Analog Ground
Pin 18	Analog Input 0 - ve (do not apply voltages outside the voltage range the K-Box is

	configured for).
Pin 19	Analog Input 1 - ve (do not apply voltages outside the voltage range the K-Box is configured for).
Pin 20	Analog Input 2 - ve (do not apply voltages outside the voltage range the K-Box is configured for).
Pin 21	Analog Input 3 - ve (do not apply voltages outside the voltage range the K-Box is configured for).
Pin 22	Analog Input 4 - ve (do not apply voltages outside the voltage range the K-Box is configured for).
Pin 23	Analog Input 5 - ve (do not apply voltages outside the voltage range the K-Box is configured for).
Pin 24	Analog Input 6 - ve (do not apply voltages outside the voltage range the K-Box is configured for).
Pin 25	Analog Input 7 - ve (do not apply voltages outside the voltage range the K-Box is

The Thermocouple Connectors

The Thermocouple Connectors on the K-Box are miniature-size flat-type sockets.

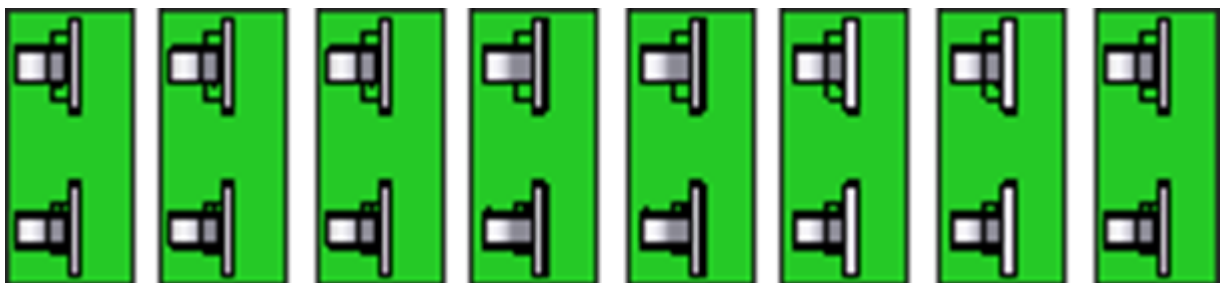

Miniature-size flat-socket type thermocouple connectors

IEC Connector

Pin Function

Top	+ Signal from the Thermocouple
------------	--------------------------------

The dimensions of the Male Flat Type Miniature Size Thermocouple Plug that you would plug into it are as follows:

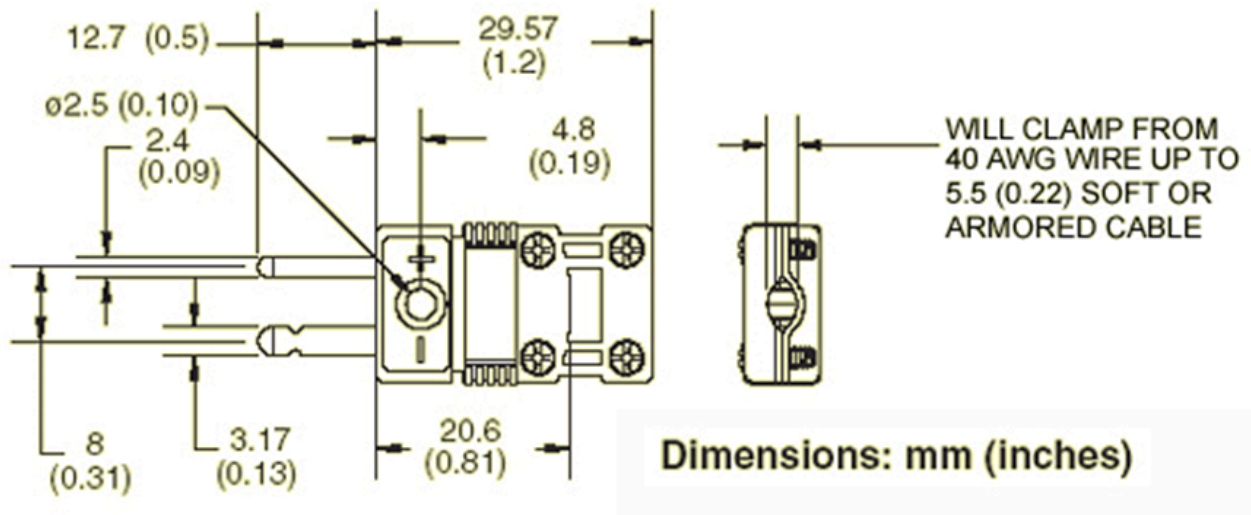

Dimensions of the Male Flat Type Miniature Size Thermocouple

Note:

- Pins not mentioned in the description table(s) are NC.