

# Accsense Wi-Fi Pro User Manual



Terry Nagy

CAS DataLoggers

8/25/2025

Rev 0.1

# TABLE OF CONTENTS

TABLE OF CONTENTS .....	2
SAFETY ALERTS .....	6
INTRODUCTION .....	7
SENSORS AND INPUT SIGNALS .....	7
ANALOG INPUTS .....	8
MEASUREMENT AND INDICATION OF INPUT TYPES .....	10
DIGITAL INPUT .....	13
DIGITAL OUTPUT .....	13
POWER, SENSOR AND SIGNAL CONNECTIONS .....	14
ELECTRICAL CONNECTIONS .....	14
POWER SUPPLY .....	15
ANALOG INPUTS .....	15
DIGITAL OUTPUT .....	17
DIGITAL INPUT .....	18
MECHANICAL INSTALLATION.....	19
DIMENSIONS.....	22
COMMUNICATIONS INTERFACES .....	23
USB .....	23
WI-FI .....	24
DISPLAY AND NAVIGATION .....	24
DISPLAY INFORMATION.....	24
OPERATION KEYS.....	26
NAVIGATION SCREENS .....	26
CONFIGURATION SOFTWARE.....	33



NXPERIENCE.....	33
NXPERIENCE MOBILE.....	33
CONFIGURING ACCSENSE WI-FI PRO WITH NXPERIENCE .....	33
GENERAL PARAMETERS.....	34
ANALOG CHANNELS PARAMETERS.....	35
DIGITAL CHANNEL PARAMETERS.....	37
CHANNELS GENERAL PARAMETERS .....	38
LOG CONFIGURATION .....	39
COMMUNICATION PARAMETERS.....	41
SETTING UP ACCSENSE CLOUD CONNECTION PARAMETERS.....	43
ALARM CONFIGURATION .....	44
DIAGNOSTICS.....	47
LOGS .....	47
CHANNELS .....	48
ALARMS .....	49
COMMUNICATION.....	49
MISCELLANEOUS .....	50
ACCSENSE CLOUD WEB SOFTWARE .....	51
CONNECTION TO ACCSENSE CLOUD PORTAL.....	51
USING A WEB BROWSER .....	51
MOBILE APP.....	51
ACCOUNTS PREFERENCES .....	52
GENERAL INFORMATION.....	52
VISUALIZATION PREFERENCES.....	53
SECURITY PREFERENCES .....	54
USERS.....	54

SENSOR SUMMARY .....	57
ALARM LIST.....	57
SENSOR LIST.....	58
DEVICES .....	61
AUDIT LOG.....	<b>Error! Bookmark not defined.</b>
NOTIFICATION LOG.....	64
ALARM LOG .....	65
USER LOG.....	65
CONFIGURATION LOG .....	66
APPENDIX A - TROUBLESHOOTING.....	67
START/STOP MODES.....	67
CLOCK .....	67
ALARM INFORMATION .....	67
ANALOG INPUTS .....	67
UNREGISTERED ALARMS .....	68
COMMUNICATION LINK LOSS.....	68
PROBLEMS COMMUNICATING WITH THE DEVICE VIA USB INTERFACE .....	68
PROBLEMS DURING FIRMWARE UPDATE VIA USB INTERFACE.....	69
APPENDIX B – UPDATING FIRMWARE .....	72
FIRMWARE UPDATE VIA USB .....	72
OVER THE AIR (OTA) FIRMWARE UPDATE.....	72
APPENDIX C - TECHNICAL SPECIFICATIONS .....	73
SENSORS RANGE AND ACCURACY .....	74
WIRELESS CONNECTIVITY .....	77
APPENDIX D - NXPERIENCE MOBILE SPECIFIC FEATURES.....	78
INSTALLING THE APPLICATION .....	78

OPERATION OF THE APPLICATION .....	78
DOWNLOAD LOGS .....	79
MONITORING .....	87
FILE MANAGER .....	90
APPENDIX E - CERTIFICATIONS .....	95
FCC.....	95
IC.....	95
CE Mark / UKCA .....	95
ANATEL .....	95
NORM CISPR 22 .....	96
APPENDIX F - WARRANTY.....	97

## SAFETY ALERTS

The symbols below are used throughout this manual to draw the user's attention to important information regarding safety and use of the device.

		
<b>CAUTION</b> Read the manual fully before installing and operating the device.	<b>CAUTION OR HAZARD</b> Risk of electric shock.	<b>ATTENTION</b> Material sensitive to static charge. Check precautions before handling.

Safety recommendations should be observed to ensure user safety and to prevent damage to the device or system. If the device is used in a manner other than that specified in this manual, the safety protections may not be effective.

## INTRODUCTION

**Accsense Wi-Fi Pro** is an electronic wireless data register, also known as a *data logger*, which comprises three analog sensors inputs and one digital sensor input, respectively called the "analog measuring channel" and the "digital measuring channel". With a memory capacity for up to 140,000 logs, it allows the use of batteries, to keep its autonomy and continue to log data even during external power outages. It features a large display that offers a comfortable view of measured variables and general device information. Furthermore, the device's enclosure has a protection cover for the connections, a sealing ring and a holder that allows its attachment to a wall or metal surface by means of the optional bracket with magnetic inserts.

The analog inputs accept any type of temperature sensor, such as thermocouples, Pt100 or sensors for any other quantities with current or voltage signals. The digital channel can log the time of events, such as opening a door, or counting pulses from a flow sensor. **Accsense Wi-Fi Pro** also has the following internal sensors: temperature, battery voltage, and external power supply voltage, which can also log the values in the memory, taking the place of any of the available measurement channels. Its wide display allows you to view up to three variables simultaneously, and displays indications such as alarms, communication status, enabled channels, battery voltage level, among other information.

All device configurations can be accessed by user via desktop or notebook connected to **Accsense Wi-Fi Pro** USB interface or through an Android or iOS smartphone. For use with computers, **CAS Dataloggers** provides the **Accsense NXperience** software on the website download area:

<https://dataloggerinc.com/downloads/accsense-monitoring-systems/>

For users with smartphone, the **NXperience Mobile** application is available on *Google Play Store* or *App Store* (iOS). Both software tools allow log configuration, data download, and analysis.

## SENSORS AND INPUT SIGNALS

**Accsense Wi-Fi Pro** allows users to choose, in addition to the channels to be registered and sensor types, configuration that provides flexibility to accommodate many applications. In addition, is possible to configure the device with the following parameters:

- **Log Range:** Shows frequency, in seconds, with which an acquisition must be made and logged in the memory. A low periodicity will increase battery consumption and fill up the memory faster.
  - **Minimum Range:**
    - 1 second (if no channel is configured to operate on average)
    - 10 seconds (if a channel is configured to operate on average)
  - **Maximum Range:** 18 hours.
- **Display Update Range:** Shows frequency, in seconds, with which an acquisition must be made and updated on the display. It allows you to save memory by configuring it to a larger range of logs without damaging the Display update rate. Low frequency increases battery consumption. This range can be disabled if set to '0'. Thus, the display update will take place in the log range.

- **Minimum Range:** 1 second
- **Maximum Range:** 1 hour

When configuring a Display Update Range, it should be less than the Log Range. Otherwise, it will be ignored, and the display will be updated at the same Log Range.

The Display Update Range only updates Analog Channels that are not configured to operate on average. Thus, the Digital Channel that is configured to operate in counting mode and the Analog Channels that are configured to operate on average will only have their information updated at each log range.

If the digital channel is operating in the "Event Log" mode, each event will update its respective information on the display.

## ANALOG INPUTS

**Accsense Wi-Fi Pro** has three channels for reading analog signals. The types of signals and sensors accepted by them are:

- **Temperature Sensors:**
  - RTD, Pt100
  - Thermocouples J, K, T, N, E, R, S, and B
  - Internal Temperature Sensor
- **Linear Sensors:**
  - 0 to 50 mV
  - 0 to 5 V
  - 0 to 10 V
  - 0 to 20 mA
  - 4 to 20 mA
- **Internal Diagnostic Sensors:**
  - Battery Voltage
  - External Power Supply Voltage

Each type has specific operation configurations and characteristics. Its configurations and characteristics are described below:

- **Temperature Sensors:**
  - Inform the measured temperature within the possible measuring range of each sensor.
  - The maximum resolution for the Temperature Sensors is 0.1 °C.
  - You can configure them to be displayed with one or no decimal places.
  - You can configure them to be displayed in units of measure °C or °F.

- **Linear Sensors:**

- Displays the value within the range required by the user (defined by the parameter "User Range"), as configured in the "Lower Limit", "Upper Limit", and "Number of Decimal Places" parameters.
  - **Number of Decimal Places:** Allows you to choose to use 0, 1, or 2 decimal places.
  - **Lower Limit:** Corresponds to the value configured to represent the minimum value of the chosen sensor:
    - Minimum -19999 to 0 decimal places
    - Minimum -1999.9 to 1 decimal place
    - Minimum -199.99 to 2 decimal places
  - **Upper Limit:** Corresponds to the value configured to represent the maximum value of the chosen sensor:
    - Maximum 19999 to 0 decimal places
    - Maximum 1999.9 to 1 decimal place
    - Maximum 199.99 to 2 decimal places
- You can configure them to be displayed in units of measurement °C, °F or in a custom unit of up to 8 characters, which will not show on the display.
- The maximum resolution for linear sensors corresponds to a ratio between the user range and the maximum resolution of the chosen sensor.

- **Internal Diagnostic Sensors:**

- Displays the voltage of the possible **Accsense Wi-Fi Pro** power supply sources.
- The maximum resolution for the internal diagnostic sensors is 0.01 V.
- You can configure them to be displayed with 0, 1, or 2 decimal places.
- The unit of measure for these sensors is Volts and no unit symbol is displayed.

Refer to the [Technical Specifications](#) chapter to check these signals' accuracy. Refer to the [Installation](#) chapter to check these signals' connection.

An analog/digital (A/D) converter with high resolution and accuracy is used to read the sensors connected to the analog channel inputs. In the desired scan range, all the analog channels enabled will be read.

Each type of input signal has a valid measuring range (see the chapter [Technical Specifications](#)). However, the device can typically measure signals which slightly exceed the limits of this range. The amount it can measure beyond it, however, depends on the type of input configured and can vary between different devices.

The following table describes the input types supported by the device, the device's signal conditions and their respective indications.

## MEASUREMENT AND INDICATION OF INPUT TYPES

INPUT TYPE	INPUT SIGNAL CONDITION	INDICATION
<b>Pt100</b>	Within range	Read input value
	Pt100 with one or more wires disconnected	---- will be displayed -22000 will be logged in the memory
	Slightly above the upper limit	Read input value *
	Slightly below the lower limit	Read input value *
	Far above the upper limit	<b>UUUU</b> will be displayed 32767 will be logged in the memory
	Far below the lower limit	<b>NNNN</b> will be displayed -32000 will be logged in the memory
<b>Thermocouples J, K, T, E, N, R, S and B</b>	Within range	Read input value
	Open Thermocouple	---- will be displayed -22000 will be logged in the memory
	Slightly above the upper limit	Read input value *
	Slightly below the lower limit	Read input value *
	Far above the upper limit	<b>UUUU</b> will be displayed 32767 will be logged in the memory
	Far below the upper limit	<b>NNNN</b> will be displayed -32000 will be logged in the memory
<b>Voltage 0 to 50 mV</b>	Within range	Read input value converted into User
	Signal disconnected	---- will be displayed -22000 will be logged in the memory
	Slightly above the upper limit	Read input value converted into User Range *
	Slightly below the lower limit	Read input value converted into User Range *
	Far above the upper limit	<b>UUUU</b> will be displayed 32767 will be logged in the memory
	Far below the lower limit	<b>NNNN</b> will be displayed -32000 will be logged in the memory
<b>Voltage 0 to 5 V</b>	Within range	Read input value
	Signal disconnected	0 V converted into User Range

INPUT TYPE	INPUT SIGNAL CONDITION	INDICATION		
<b>0 to 10 V</b>	Slightly above the upper limit	Read input value converted into User Range *		
	Slightly below the lower limit	Read input value converted into User Range *		
	Far above the upper limit	<b>UUUU</b> will be displayed 32767 will be logged in the memory		
	Far below the lower limit	<b>NNNN</b> will be displayed -32000 will be logged in the memory		
<b>Current 0 to 20 mA 4 to 20 mA</b>	Within range	Read input value converted into User Range		
	Signal disconnected	<b>0 a 20 mA</b>	0 mA converted into User Range	
		<b>4 a 20 mA</b>	<b>----</b> will be displayed -22000 will be logged in the memory	
	Slightly above the upper limit	Read input value converted into User Range *		
	Slightly below the lower limit	<b>0 a 20 mA</b>	It is not possible to decrease more than the lower limit	
		<b>4 a 20 mA</b>	Read input value converted into User Range *	
	Far above the upper limit	<b>UUUU</b> will be displayed 32767 will be logged in the memory		
	Far below the lower limit	<b>0 a 20 mA</b>	It is not possible to decrease more than the lower limit	
<b>4 a 20 mA</b>		<b>NNNN</b> will be displayed -32000 will be logged in the memory		

(\*) **Note:** The analog channel indication continues slightly beyond the limits specified for the selected input type. However, in this condition, accuracy is not guaranteed.

**Table 1 –** Measurement and indication of input types by **Accsense Wi-Fi Pro**

**Accsense Wi-Fi Pro** allows you to configure settings to be applied to analog sensor readings. These settings can be used to correct errors in the sensor or process in which the sensor is installed and applied individually for each analog channel. Two adjustment modes are provided by the device:

- **Offset:** Allows each analog channel to choose an Offset value to be added to the channel reading indication. It is a simple and fast feature to adjust the display throughout the range.
- **Custom Calibration:** Allows you to enter up to 10 set points for each channel to correct distortions in reading these channels at these points. We call this characteristic a "custom calibration" because it allows the user to adjust the indication at the desired points by zeroing their errors. The adjustment is made linearly between the points entered, according to the values entered.

It is important to note that both the Offset adjustment and the insertion of custom calibration points are optional, only indicated for those who wish to adjust the indication to a local standard, since the **Accsense Wi-Fi Pro** has already been calibrated at the factory.



**Whenever you change the input type, make sure that the custom calibration points of the previous input are deleted!**

For each analog channel, a unique (Tag) name must be assigned, which will be used to reference the channel. You should also choose the type of input (sensor) that will be connected to that channel. In addition to that, you can assign the unit of measured value: for temperature sensors (Pt100 or thermocouples), degrees Celsius (°C) or Fahrenheit (°F); for linear sensors (current or voltage), you can enter the desired unit.

In the case of linear input types, one must choose the sensor indication range, that is, what the channel should indicate when the input is at its minimum value and what it should indicate when it is at its maximum value (minimum and maximum values considering the **Accsense Wi-Fi Pro** working range for the chosen input type). Once the 4 to 20 mA input type is chosen, for example, a pressure transmitter from 0 to 2 bars will be connected. In this case, "0.0" must be chosen as the minimum value and "2.0" as the maximum value in the input configuration. All resolution and accuracy available will be contained within the chosen range.

When a simulator is used on analog inputs that are connected to the mains (e.g. a thermocouple or voltage simulator) and it is not isolated, it is recommended to use a different reading interface than USB. In some cases, it is possible to observe noise and measurement created by the influence of the USB cable connection, potential by ground loops.

The **Accsense Wi-Fi Pro**, when operated by batteries, keeps the entire analog circuit switched off while no acquisition is being made. This strategy is necessary so that it can operate for more than two years without needing to change batteries. This characteristic may cause some undesirable effects during calibration, as some analog signal simulators (e.g., thermocouples simulator or a Pt100) may not operate properly, causing false reading offsets and oscillations. Should such a problem be identified, it is recommended to power the **Accsense Wi-Fi Pro** by external source while using a simulator.

Setting the local network frequency (50 Hz or 60 Hz) is important as it helps improve the performance of reading analog channels even while the device is running on battery power. Usually, the power grid causes interference in the signal read from the sensors, which can be more easily mitigated if the correct frequency filtering is applied.

## DIGITAL INPUT

**Accsense Wi-Fi Pro** has a Digital Input channel that can be configured for "Pulse Count", "Event Log", or even for "Logs Control" modes. This Digital Input can be disabled.

Regardless of the function for which it will be used, you must configure the type of sensor output that will be connected to the input: PNP, NPN, or Dry Contact (refer to chapter [Installation](#) to see how the sensors should be connected). In addition to that, it is necessary to select the edge of interest of the digital signal to generate the count, event, or start/end of logs: rising edge, falling edge, or both edges.

Relationship between Sensor Type, Sensor Status, and Logical Level obtained in Accsense Wi-Fi Pro		
Sensor Type	Sensor State	Logical Level
PNP	Open	0
	Closed	1
NPN	Open	1
	Closed	0
Dry Contact	Open	1
	Closed	0

Table 2 – Digital Input

For Dry Contact sensors, it is necessary to set a *debounce* time of at least 50 ms (sensor stabilization time / time in which the sensor must remain in the state of interest for it to be considered valid). For PNP or NPN type sensors, if configured in "Pulse Count" mode, it is not necessary to set a *debounce* time. However, if the digital input is configured for the "Event Log" or "Logs Control" modes, a minimum *debounce* of 50 ms is required to prevent any noise from generating a false event. In the "Event Log" and "Logs Control" modes, events will be generated after the end of the *debounce* time.

## DIGITAL OUTPUT

The **Accsense Wi-Fi Pro** has a PNP-type Digital Output which when triggered places the voltage from the external power supply to the respective terminal and can be disabled or configured to operate in one of the modes described below:

- **Auxiliary Electronic Switch:** Allows you to control the power supply of external instruments during analog channel readings. 4-20 mA transmitters, for example, can be fed by the digital output pin, so that they are only turned on when they are read – which would save energy from the **Accsense Wi-Fi Pro** external power supply, which can be a 12 V battery. In the "Auxiliary Electronic Switch" mode, it will be necessary to configure how long before each acquisition the digital output must be triggered.
  - **Drive Time:** It defines, in seconds, how long before each acquisition the digital output must be triggered. It will be deactivated when the acquisition is ready. Such time cannot be longer than the lowest acquisition range (Instant, Average = 1/10 of the snapshot, Interval of Display Range). If equal to 0, the Auxiliary

Electronic Switch will be enabled at the exact moment of an acquisition. If greater than or equal to the lowest acquisition range, the Auxiliary Electronic Switch will remain be enabled.

- **Alarm Status:** Allows you to follow the current general alarm status. If any channel is in an alarm situation, the Digital Output will be triggered. If no channel is set to alarm, the Digital Output will be disabled.

## POWER, SENSOR AND SIGNAL CONNECTIONS

### ELECTRICAL CONNECTIONS

**Accsense Wi-Fi Pro** has 4 detachable connection terminal blocks for connection of external power supply, digital output load, digital input sensor, and analog sensors for each of the 3 available analog channels. Figure below illustrates electrical connections in a basic way:

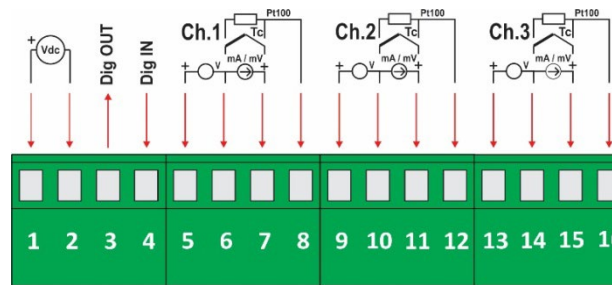

Figure 1 – Electrical connections

For the sensors connection, it is recommended that the connection terminal blocks be previously detached from the device. To streamline the sensors connection, it is necessary to use the enumeration printed on the connectors and the Electrical Connections image in the figure above, and in the Connections' Protection Cover.



**The power supply, digital output, digital input, and analog inputs terminals are not isolated from each other!**

**Therefore, analog, and digital signals from the same voltage source must not be used, otherwise the device will malfunction.**

## POWER SUPPLY

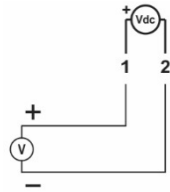

The connection to the Power Supply is made at the terminals according to the following image. The power supply used must be of the direct current type, with a voltage between 10 and 30 V and provide a minimum current of 15 mA when no load is connected to the digital output. If the load is connected to the digital output, the source used must be able to provide current compatible with the load used.

## ANALOG INPUTS

### PT100 CONNECTION

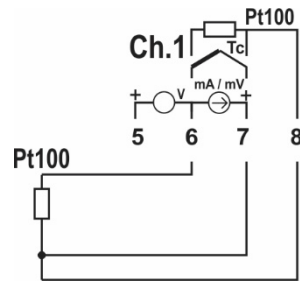

The connection to the channels is made at the terminals according to the following image. The three-wire connection from the Pt100 sensor element to the **Accsense Wi-Fi Pro** input guarantees the error cancellation caused by the wires resistance. The three wires should have the same gauge and length.

For two wire PT100, connect the RTD to terminals 6+7 and link 7 to 8.

### THERMOCOUPLE CONNECTION

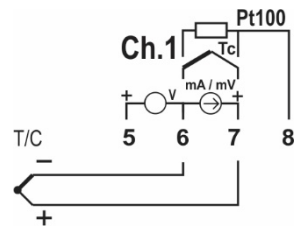

The connection to the channels is made at the terminals according to the following image. You must observe a correct connection polarity.

Cables used for thermocouples connection must have the same thermoelectric characteristics of the thermocouple used (compensation cable or extension cable) and must be connected with the correct polarity.

Failure to use compensation cables or their use with incorrect polarity can lead to large measurement errors.

### VOLTAGE CONNECTION (mV)

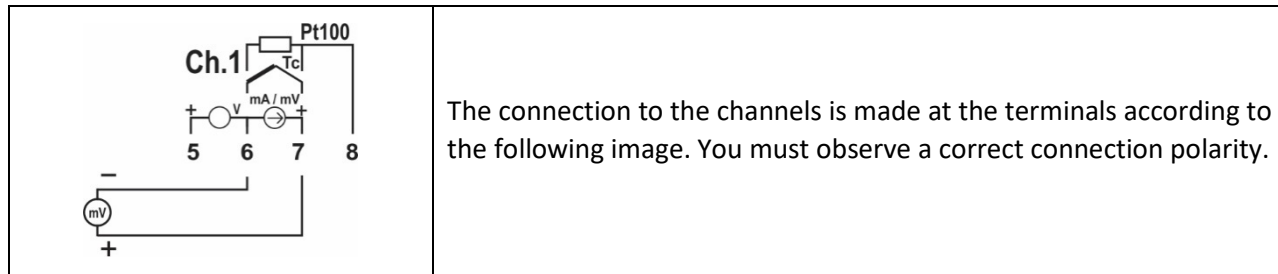

### CURRENT CONNECTION (mA)

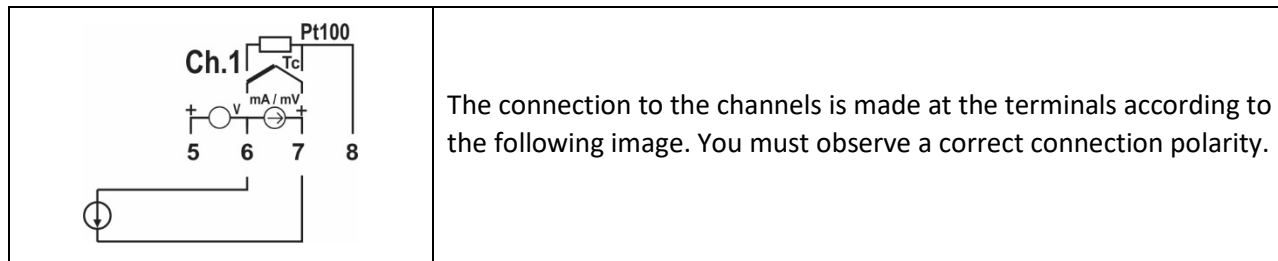

### VOLTAGE CONNECTION (V)

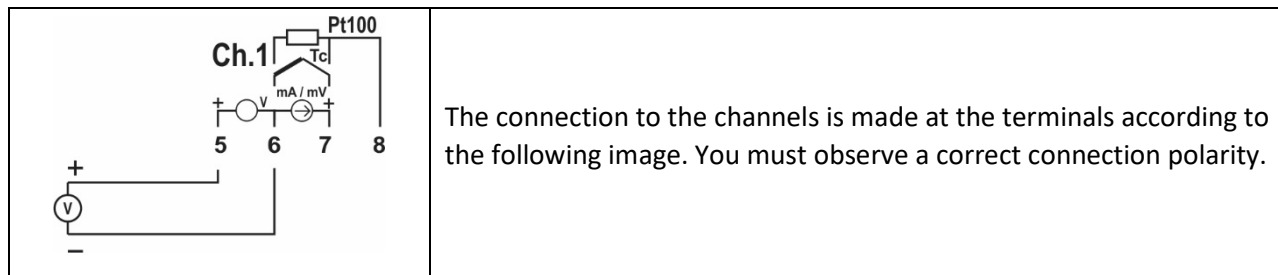

**EXAMPLE OF CONNECTION OF 4-20 MA TRANSMITTERS POWERED BY THE CURRENT LOOP**

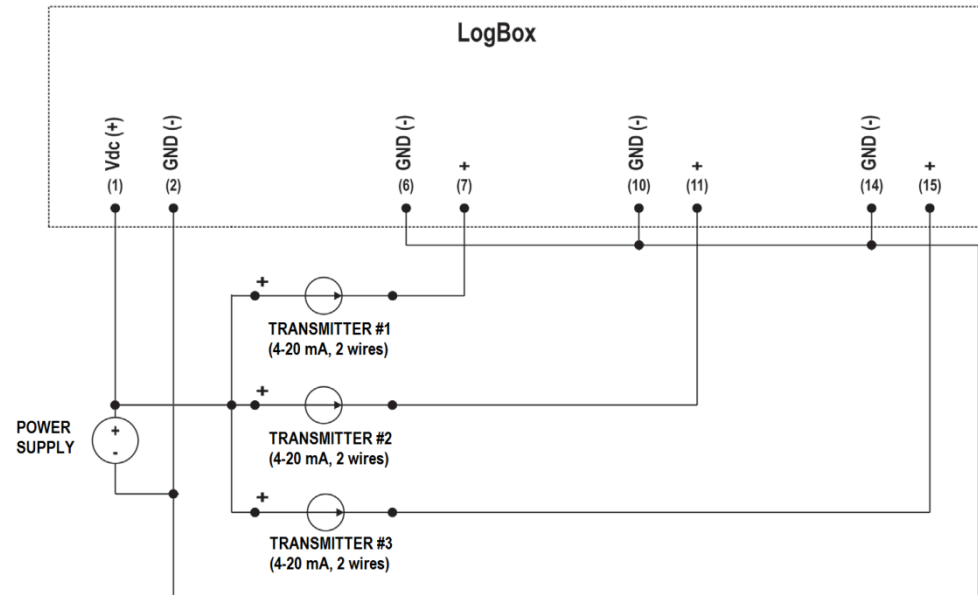

**Figure 2 –** Example of connecting transmitters that are fed by the loop

**DIGITAL OUTPUT**

**ALARM STATUS MODE CONNECTION**

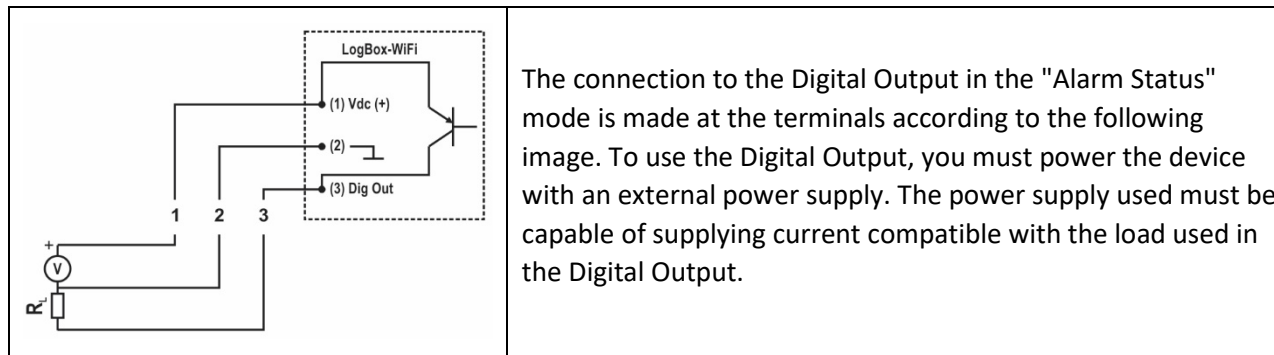

The connection to the Digital Output in the "Alarm Status" mode is made at the terminals according to the following image. To use the Digital Output, you must power the device with an external power supply. The power supply used must be capable of supplying current compatible with the load used in the Digital Output.

**CONNECTION IN "AUXILIARY ELECTRONIC SWITCH" MODE**

The connection to the Digital Output in the "Auxiliary Electronic Switch" mode, used to power current transmitters, is made at the terminals according to the figure on the side. To use the Digital Output, you must power the device with an external power supply. The source used must be able to provide current compatible with the number of transmitters used.

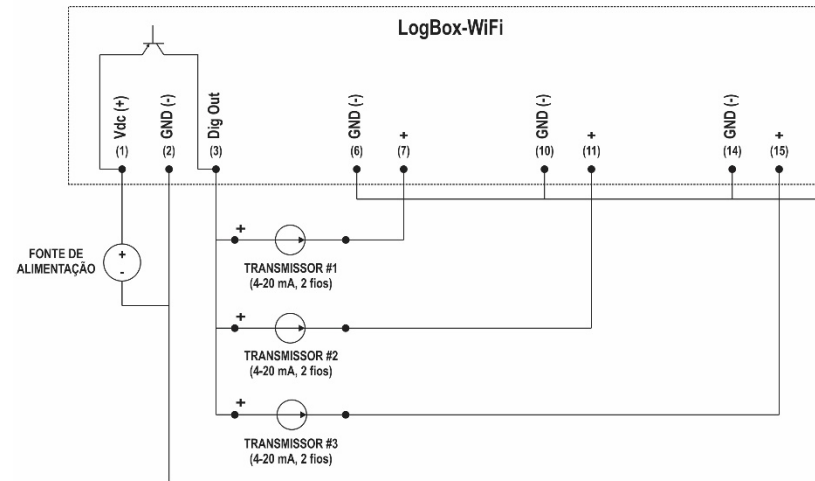
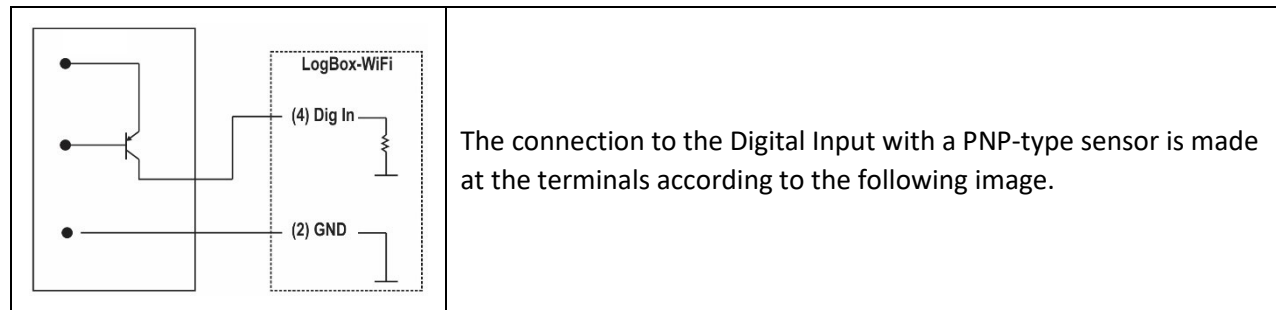

Figure 3 – Connection in "Auxiliary Electronic Switch" Mode

## DIGITAL INPUT

### PNP CONNECTION

Sensor



### NPN CONNECTION

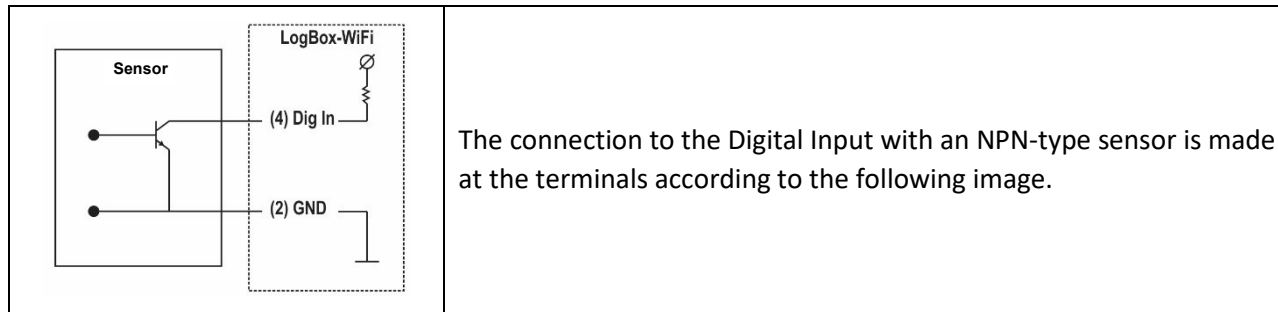

### DRY CONTACT CONNECTION

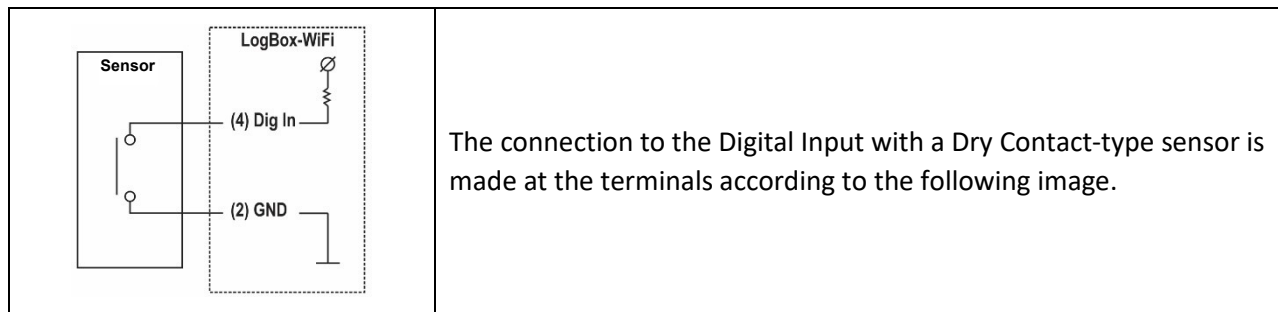

## MECHANICAL INSTALLATION

**Accsense Wi-Fi Pro** has a high-quality casing, built in ABS + PC and with IP40 protection index.

To streamline the **Accsense Wi-Fi Pro** attachment, the device comes with a mounting bracket designed for wall mounting, which has three oblong holes, arranged in a triangle, made to fix it using screws. Optionally, to facilitate the fixation on metal surfaces, it is possible to purchase the device model that comes with a fixing bracket with magnetic inserts.

To assist in the installation aesthetics, two openings in the lower part of the fixing bracket can be used to pass the sensors that are connected to the device. In addition to that, this bracket has a ring that allows the placement of a padlock preventing **Accsense Wi-Fi Pro** from being removed from the installation location.

With the help of two screwdrivers and through two lateral fittings, it is possible to fix or remove the **Accsense Wi-Fi Pro** from the bracket.

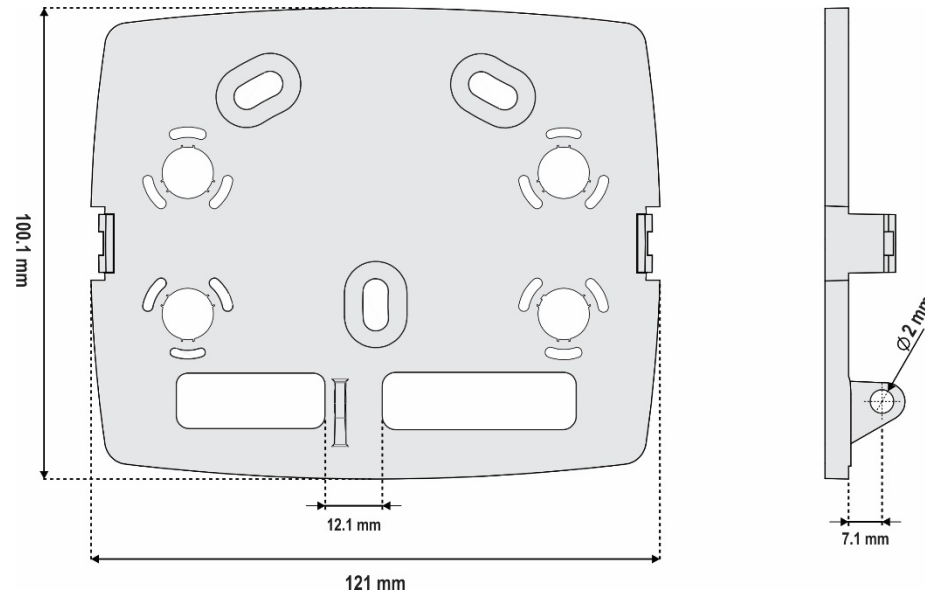

Figure 4 – Mounting bracket

To improve the device installation aesthetics, the **Accsense Wi-Fi Pro** comes with a protection cover for the connections, which is lockable in the bottom of the device and that hides its sensors. This protection cover has four detachable cavities to facilitate sensor installation.



Figure 5 – Connections' Protection Cover

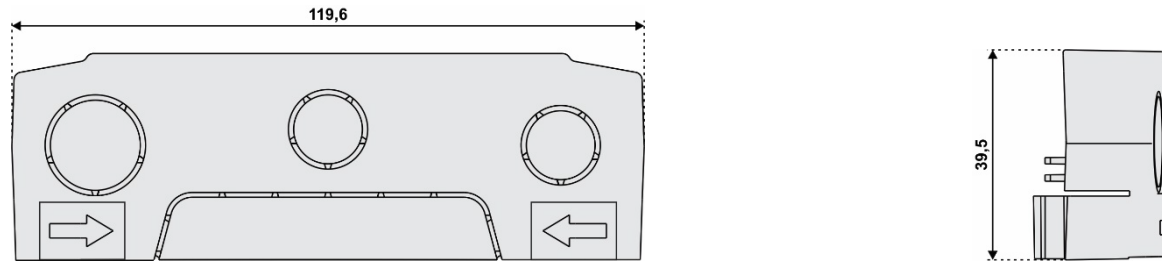

Figure 6 – Dimensions of protection cover detachable connections and cavities

To detach the protection cover, you must press the sides, one side at a time.



Figure 7 – Removing the protection cover

To attach the protection cover, it is necessary to press the area designated by the arrows and push one side at a time from the outside.

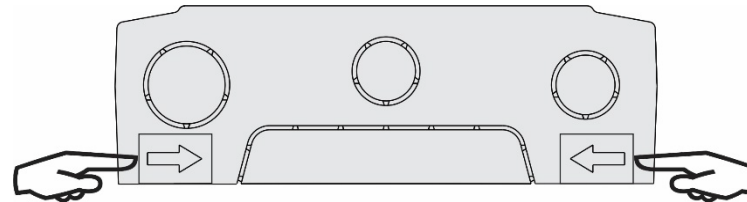

Figure 8 – Fitting the protection cover

## DIMENSIONS

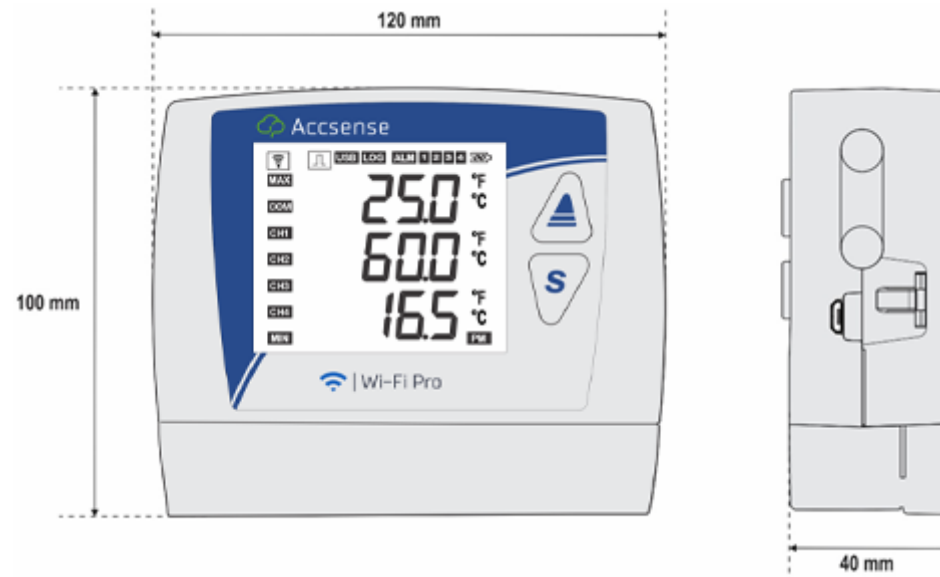

Figure 9 – Accsense Wi-Fi Pro dimensions

To open the battery compartment, press the cover in the arrows region and push it in from the inside out.

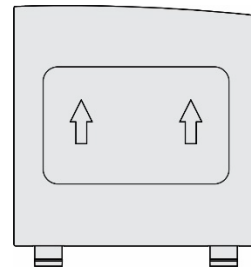



Figure 10 – Batteries cover

## COMMUNICATIONS INTERFACES

### USB

The USB interface is the preferred interface for configuring, monitoring, and downloading device logs. It is the only interface which can never be disabled. To access it, you must install **NXperience** for Windows. This way, the USB driver will be installed (see chapter [NXperience](#)). A standard micro-USB cable must be used for desktop or notebook connection.

When connecting the USB cable, the respective icon should light up on the device's display, indicating that its interface is ready for use. On first use, you must wait for Windows to automatically install the driver already preinstalled by **NXperience**. The device's configuration, monitoring and data download, made through the USB interface, must be performed by **NXperience**.

 	<p><b>The USB interface is NOT isolated.</b></p> <p><b>Its purpose is temporary use during CONFIGURATION, MONITORING, and LOG DOWNLOAD. For the safety of people and devices, it should only be used when the device is disconnected from the external power supply.</b></p> <p><b>It is possible to use the USB interface in any other connection condition, although the decision requires a careful analysis by the person in charge of installation.</b></p>
------------------------------------------------------------------------------------------------------------------------------------------------------------------------	------------------------------------------------------------------------------------------------------------------------------------------------------------------------------------------------------------------------------------------------------------------------------------------------------------------------------------------------------------------------------------------------------------------------------------------------------------------

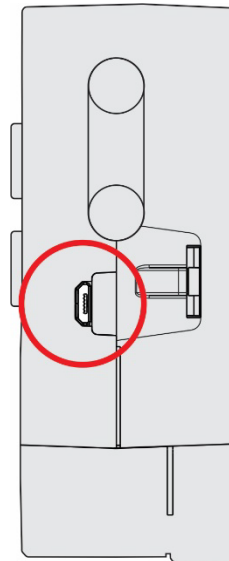



Figure 11 – USB cable connection

## WI-FI

**Accsense Wi-Fi Pro** has an 802.11 interface in 2.4 Ghz b/g/n standards for sending registered data through protocols compatibles with the device. The Wi-Fi interface also sends some device's configuration parameters of the **Accsense Wi-Fi Pro** through these same protocols.

This interface supports WPA-Personal (PSK) WPA/WPA2 TKIP/AES/TKIP and AES encryption.

If the Wi-Fi interface is enabled and the device is connected to a Wi-Fi network, the  symbol will remain lit. While data is being sent through this interface, the symbol  will remain lit.



**While the Accsense Wi-Fi Pro is operating on batteries and to reduce power consumption, Wi-Fi will remain disabled. All other features of the device, however, remain operable for at least one year.**

**When power from the power supply is restored, the Wi-Fi interface will be activated, and the data recorded in memory during the power interruption will be published.**

## DISPLAY AND NAVIGATION







### DISPLAY INFORMATION

**Accsense Wi-Fi Pro** has an LCD display with 3 numerical lines of 4 ½ digits, to display the current value of all enabled channels, as well as the minimum and maximum values thereof. At the same time, it is possible to display the current value of up to three analog channels and, in a second screen, if enabled, the digital input current value. In addition to channel information, **Accsense Wi-Fi Pro** has 7 screens with a variety of information and features and 24 symbols that allow for easy information visualization and diagnostics.

See below an illustration of the display with a description of each symbol's functionality.





Figure 12 – Accsense Wi-Fi Pro Display Information

- : It remains lit while **Accsense Wi-Fi Pro** has a valid IP on the wireless network to which you are connected. If the device is set to wake up by keyboard, it will remain on while the interface remains available.
- : When the digital channel is disabled, it remains off. When set to "Pulse Count" mode, it will remain on. When set in the "Event Log" or "Logs Control" modes, it will remain lit, flashing when an event is detected at the digital input.
- **USB**: Lights up when the USB cable is connected. Turns off when the USB cable is disconnected.
- **LOG**: It remains lit from the moment the device registers the first log until the moment it stops logging. When set to "Daily" mode, which must start and end daily at a predetermined time, it will remain lit within the set time. It will flash while logging, turn off at the time of a log and restart.
- **ALM**: Lights up and stays on when entering an alarm condition. Turns off when a new configuration is received, or the alarm status is cleared. Indicates to the user that, at some point, an alarm has been triggered.
- **1, 2, 3, 4**: Light up while the alarm conditions of the corresponding channels are satisfied: 1 (analog channel 1), 2 (analog channel 2), 3 (analog channel 3) and 4 (digital channel). When you exit the alarm condition, the flag will be cleared.
- : Indicates the battery voltage level. This symbol is updated next to the log range (even if the device is not logging), with a minimum of 5 minutes. Thus, if the device is configured to log every 1 second, the battery indicator will refresh every 5 minutes. If the logging interval is longer than 5 minutes, the battery indicator will update with the same log range.
  - : Battery over 75 %
  - : Battery over 50 %
  - : Battery over 25 %
  - : Battery below 25 % (provide battery replacement)

- **MAX**: Lights up while the "Maximum" values information reached in each channel are being displayed.
- **COM**: Flashes to inform the receipt of valid data packet from one of the available communication interfaces.
- **CH1**, **CH2**, **CH3**, **CH4**: Indicates which channels are enabled.
- **MIN**: Lights up while the "Minimum" amount of information is being displayed.
- **°F**, **°C**: If the channel unit is set to °F or °C, one of the symbols will light up during channel display. Otherwise, no unit symbol will be displayed.
- **PM**: If the clock is set in the 12-hour format, the PM symbol will light up when the clock is displayed, and the time is later than 1 pm.



## OPERATION KEYS

To navigate between the screens, **Accsense Wi-Fi Pro** has 2 keys:  . Each key, depending on the current navigation screen, has two or more features:

- Short touch (less than 2 seconds):
  - Proceeds to the next screen if the current screen mnemonic is being displayed.
  - Displays the mnemonic of the current screen again if the screen information is being displayed.
- Long touch (longer than 2 seconds or held down):
  - Takes an action within the current screen.
- Both keys held down (longer than 2 seconds or held down):
  - Takes a second action within the current screen.











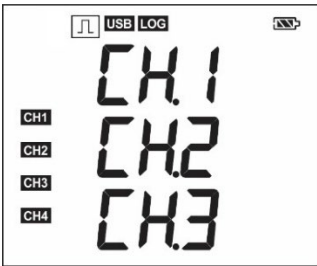
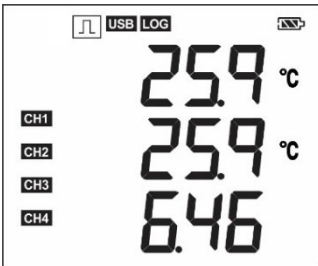

If the buzzer is active, pressing any key will mute it.

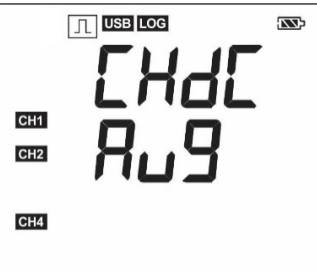
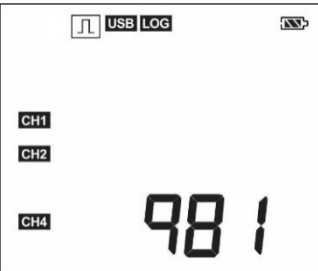



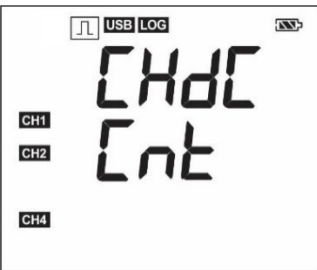
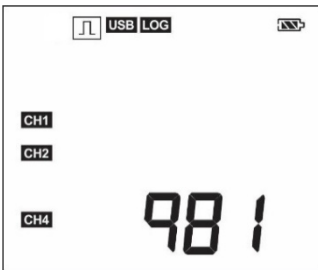





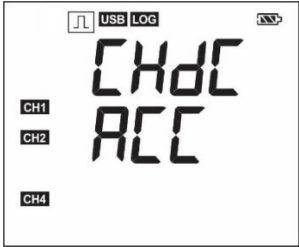
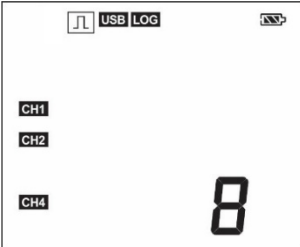

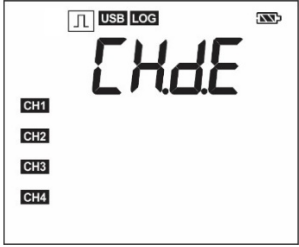

## NAVIGATION SCREENS





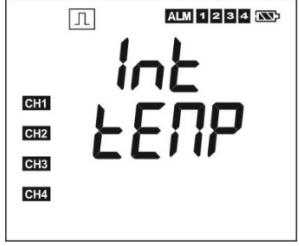
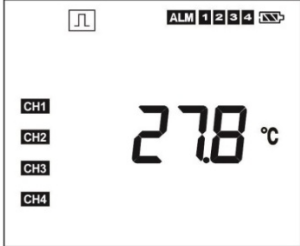









To streamline information identification on each screen, a mnemonic, which will remain visible for two seconds, will be displayed when pressing a key. If no key is pressed for this period, the information on the current screen will be displayed. If the  key or the  key is pressed while a mnemonic is being displayed, the device will advance to the next screen or return to the previous one, which will be properly specified by their mnemonics.









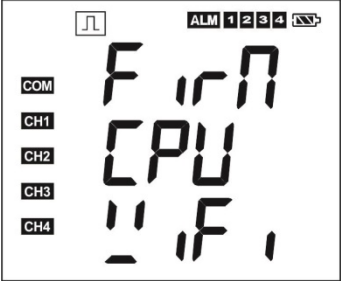
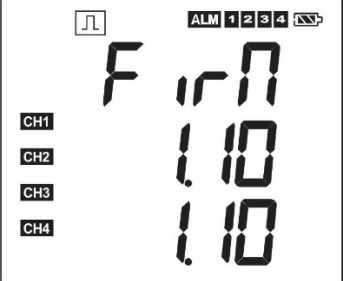

When the device is displaying the information on a screen, simply press any of the two keys to make the mnemonic appear again. To access the desired screen, just wait two seconds.



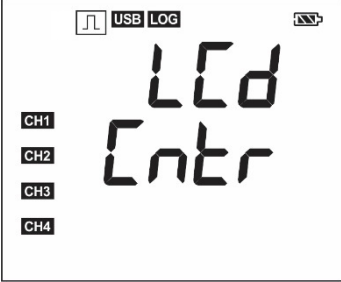







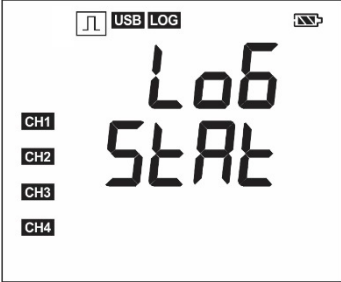
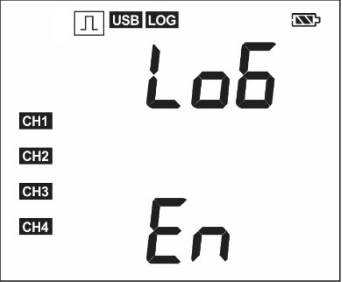

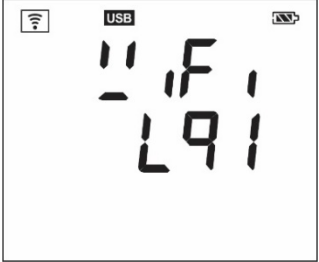

The table below shows all screens, mnemonics, and information about them, the description of each information and keys function of each screen available in the device.





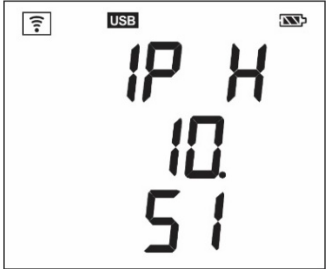

SCREEN	MNEMONIC	INFORMATION	DESCRIPTION	KEYS FUNCTION
1. Analog Inputs	 <p>Displayed for 2 seconds before accessing the "Analog Inputs" screen.</p>	 <p>This screen will be updated by the log range and/or by the display update.</p>	<p>Displays the current value of the analog channels and allows the display of the maximum and minimum values reached by each channel.</p> <p>Line 1: Analog channel 1 value.</p> <p>Line 2: Analog channel 2 value.</p> <p>Line 3: Analog channel 3 value.</p>	 Key held down or long touch: Informs the maximum value reached in each analog channel.
				 Key held down or long touch: Informs the minimum value reached in each analog channel.
				 Both keys held down: Clears the alarm statuses and the minimum and maximum values reached by each analog channel.
2. Digital Input Pulse Count: Flow Rate	 <p>Displayed for 2 seconds before moving to analog inputs – Pulse Count: Flow Rate screen.</p>	 <p>This screen is updated by the display update interval.</p>	<p>When enabled and configured in "Pulse Count" mode and then configured with the "Average Flow by Acquisition Interval" option (<b>Application</b> parameter / <b>Flow Rate</b> function), it displays the average flow logged within the configured log interval. If it is not configured, this screen will not be displayed.</p> <p>Use the three lines of the display to display the logged flow rate.</p>	 Key held down or long touch: Informs the maximum flow rate.
				 Key held down or long touch: Informs the minimum flow rate.
				 Both keys held down: Clears the minimum and maximum values reached by each channel.
3. Digital Input Pulse Count: Count	 <p>Displayed for 2 seconds before moving to digital input screen – Pulse Count: Count.</p>	 <p>This screen is updated by the display update interval.</p>	<p>When enabled and configured in the "Pulse Count" mode and then configured with "Acquisition Interval Counting" option (<b>Application</b> parameter / <b>Count</b> function), it displays the registered count within the configured registered acquisition interval. If it is not configured, this screen will not be displayed.</p> <p>Uses the three lines of the display to display the logged count.</p>	 Key held down or long touch: Informs the maximum count rate.
				 Key held down or long touch: Informs the minimum count rate.
				 Both keys held down: Clears the minimum and maximum values reached by each channel.

SCREEN	MNEMONIC	INFORMATION	DESCRIPTION	KEYS FUNCTION
4. Digital Input Pulse Count: Accumulator	 <p>Displayed for 2 seconds before moving to digital input screen – Pulse Count: Accumulator.</p>	 <p>This screen is updated by the display update interval.</p>	<p>When enabled and configured in the "Pulse Count" mode and then set to "Volume since Last Reset" (<b>Application</b> parameter / <b>Flow Rate</b> function) or the option "Accumulated Count Since Last Reset" (<b>Application</b> parameter / <b>Count</b> function), displays the volume or count accumulated since the last digital channel reset. If it is not configured, this screen will not be displayed.</p> <p>Uses the three lines of the display to display the accumulated volume or count.</p>	 Key held down or long touch: No action.
				 Key held down or long touch: No action.
				 Both keys held down: No action.
5. Digital Input Event Log or Logs Control	 <p>Displayed for 2 seconds before accessing the digital input screen – Event Log or Logs Control.</p>	 <p>This screen is updated every time an event is detected in the digital input.</p>	<p>When enabled and configured in "Event Log" or "Logs Control" modes, it displays the last event detected at the digital input.</p> <p>Line 1: Edge detected in the event:            0 – Falling edge            1 – Rising edge</p> <p>Line 2: Day. Month of the event (if the 24-hour format is selected); Month. Day of the event (if the AM/PM format is selected).</p> <p>Line 3: Hour: Minute of the event.</p>	 Key held down or long touch: No action.
				 Key held down or long touch: No action.
				 Both keys held down: No action.
				 Key held down or long touch: Informs the minimum value reached.
				 Both keys held down: Clears the minimum and maximum values reached.
6. Internal Temperature	 <p>Displayed for two seconds before accessing the "Internal Temperature" screen.</p>	 <p>This screen will be updated with information about the internal temperature of the device.</p>	<p>Displays the internal temperature of the device.</p>	 Key held down or long touch: Informs the maximum value reached.
				 Key held down or long touch: Informs the minimum value reached.
				 Both keys held down: Clears the minimum and maximum values reached.

SCREEN	MNEMONIC	INFORMATION	DESCRIPTION	KEYS FUNCTION
7. Log Memory	 <p>Displayed for two seconds before accessing the "Log Memory" screen.</p>	 <p>This screen will be updated by the logs range.</p>	<p>Displays the number of logs in the memory and free memory percentage.</p> <p>Line 1 and 2: Number of logs recorded in the memory.</p> <p>Line 3: Free memory percentage.</p>	<p> Key held down or long touch: No action.</p> <p> Key held down or long touch: No action.</p> <p>  Both keys held down: No action.</p>
8. Date/Time	 <p>Displayed for two seconds before accessing the "Date/Time" screen.</p>	 <p>This screen will be updated by the log range and/or by the display update.</p>	<p>Displays the device's current date and time.</p> <p>Line 1: Year.</p> <p>Line 2: Month.Day.</p> <p>Line 3: Hour:Minute.</p>	<p> Key held down or long touch: No action.</p> <p> Key held down or long touch: No action.</p> <p>  Both keys held down: No action.</p> <p> Key held down or long touch: No action.</p> <p>  Both keys held down: No action.</p>

SCREEN	MNEMONIC	INFORMATION	DESCRIPTION	KEYS FUNCTION
<p>9. Firmware Version</p>	 <p>Displayed for two seconds before accessing the "Firmware Version" screen.</p>	 <p>This screen will display the device and Wi-Fi module firmware versions.</p>	<p>Displays the device and Wi-Fi module firmware versions.</p> <p>Line 2: Firmware version of the device.</p> <p>Line 3: Wi-Fi module firmware version.</p>	<p> Key held down or long touch: Increases contrast (maximum of 7).</p> <p> Key held down or long touch: Decreases contrast (minimum of 0).</p> <p>  Both keys held down: No action.</p>
<p>10. Display Contrast Adjustment</p>	 <p>Displayed for two seconds before accessing the "Display Contrast Adjustment" screen.</p>	 <p>This screen will be updated whenever the display contrast is adjusted.</p>	<p>Displays the contrast level configured for the display and allows adjustment of the display.</p> <p>Line 3: Current contrast value. Can be adjusted from 0 to 7.</p>	<p> Key held down or long touch: Increases contrast (maximum of 7).</p> <p> Key held down or long touch: Decreases contrast (minimum of 0).</p> <p>  Both keys held down: No action.</p>

SCREEN	MNEMONIC	INFORMATION	DESCRIPTION	KEYS FUNCTION
11. Log Status	 <p>Displayed for two seconds before accessing the "Log Status" screen.</p>	 <p>This screen will be updated whenever the current log status is changed.</p>	<p>Displays the current log status and allows them to be started and/or paused if the device is configured to allow keyboard start and/or end.</p> <p><b>En</b> – Enabled logs.</p> <p><b>Dis</b> – Disabled logs.</p>	<p> Key held down or long touch: Initiates logs if "By Keyboard" start mode is enabled.</p> <p> Key held down or long touch: Pause records if the "By Keyboard" end mode is enabled.</p> <p>  Both keys held down: No action.</p>
12. Wi-Fi Signal Strength	 <p>Displayed for two seconds before accessing the "Wi-Fi LQI" screen.</p>	 <p>This screen will be updated according to the Wi-Fi signal strength.</p>	<p>Displays the signal strength between the device and the Wi-Fi access point.</p>	<p> Key held down or long touch: No action.</p> <p> Key held down or long touch: No action.</p> <p>  Both keys held down: No action.</p>
13. IP High	 <p>Displayed for two seconds before accessing the "IP High" screen.</p>	 <p>This screen will be updated whenever the IP is changed.</p>	<p>Displays the first two octets of the configured IP address.</p>	<p> Key held down or long touch: No action.</p> <p> Key held down or long touch: No action.</p> <p>  Both keys held down: No action.</p>

SCREEN	MNEMONIC	INFORMATION	DESCRIPTION	KEYS FUNCTION
14. IP Low	 <p data-bbox="409 518 797 571">Displayed for two seconds before accessing the "IP Low" screen.</p>	 <p data-bbox="835 518 1223 571">This screen will be updated whenever the IP is changed.</p>	Displays the last two octets of the configured IP address.	<p data-bbox="1671 209 2074 268"> Key held down or long touch: No action.</p> <p data-bbox="1671 304 2074 400"> Key held down or long touch: No action.</p> <p data-bbox="1671 437 2074 533">  Both keys held down: No action.</p>

Navigation Keys

## CONFIGURATION SOFTWARE

### NXPERIENCE

The **NXperience** software is the main tool for configuring, and downloading data for **Accsense Wi-Fi Pro**. It allows for exploring all features and features of the device by communicating through its USB interface. It is also a complete tool for analyzing data logged by the **Accsense Wi-Fi Pro**.

**NXperience** allows for joint graphic analysis of multiple data, performing mathematical calculations, issuing reports, and exporting data to several formats and is a complete configuration tool for the new **NOVUS** device line.

This manual describes the software's generic features. For instructions about device configuration, refer to the specific operating manual. The software can be downloaded free of charge from our website [www.dataloggerinc.com](http://www.dataloggerinc.com), in the Downloads area.



**Each time the device receives a new configuration through NXperience, the data in the logs internal memory will be erased and, therefore, there will be no publication By MQTT until new data is logged.**

**When a memory download is performed by NXperience, there will be a pause in the MQTT publication until the download is finished.**

### NXPERIENCE MOBILE

The **NXperience Mobile** application is the ideal tool for local management of the **Accsense Wi-Fi Pro**. Available for Android and iOS smartphones, the application offers convenience for monitoring or downloading data from the device. Through the Android or iOS sharing feature, you can export your registers data by email or store it in *Google Drive*, *Dropbox*, and any other Cloud storage tool.

**NXperience Mobile** can be downloaded for free from the Google Play Store or App Store.

The specific **NXperience Mobile** features are described in the [NXperience Mobile Specific Features](#) section.

### CONFIGURING ACCSENSE WI-FI PRO WITH NXPERIENCE

It is possible to configure **Accsense Wi-Fi Pro** by clicking the **Configure** button, located both on the **NXperience** (Windows) software home screen and on the **NXperience Mobile** application home screen, which has Android and iOS versions.

## GENERAL PARAMETERS

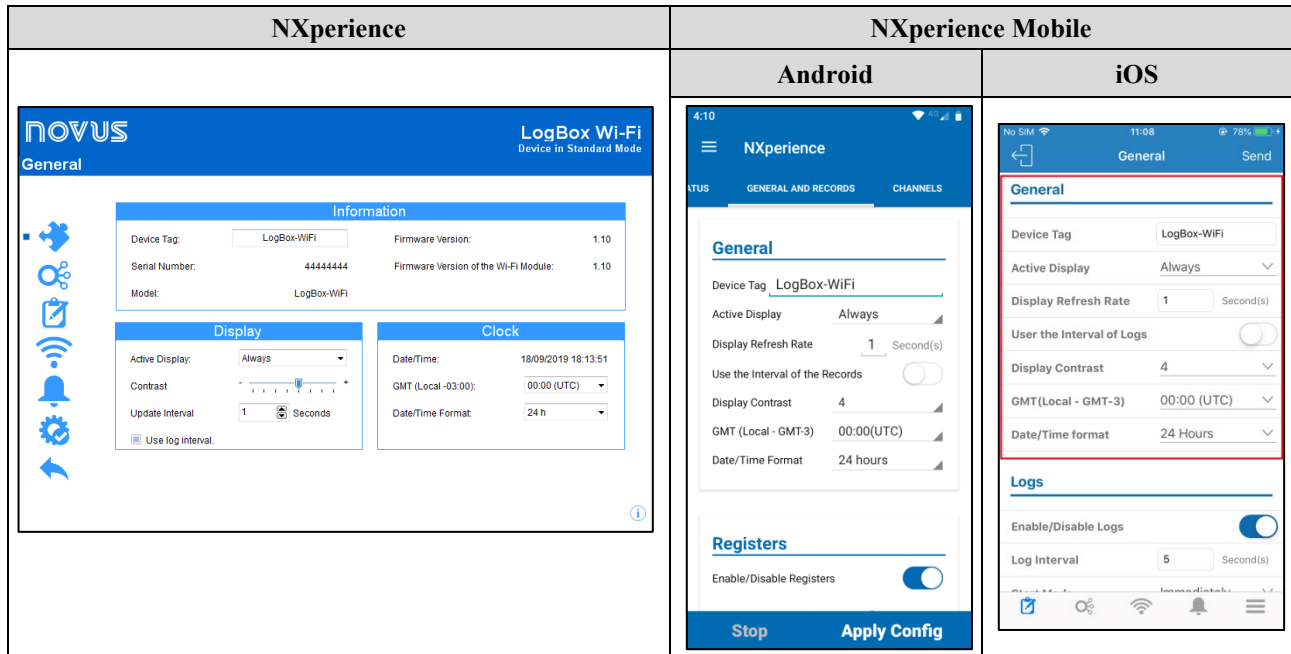

Figure 13 – General Parameters Screen

### INFORMATION

- **Device Tag:** Allows you to set a name, which will be used as channel identification during a download, for the digital channel. The field accepts up to 16 characters.
- **Serial Number:** Shows the device unique identification number.
- **Firmware Version:** Shows the firmware version recorded in the device.
- **Firmware Version of the Wi-Fi Module:** Shows the firmware version of the device's Wi-Fi module.
- **Model:** Displays the device model name.

### DISPLAY

- **Active Display:** Allows you to configure when the display should become active.
  - **Always:** If configured, it will keep the display active, following the configured contrast and update range.
  - **By Keyboard:** If configured, the display will be activated whenever a key is pressed and will remain active for 1 minute (until a key is pressed again). This setting will follow the configured contrast.
  - **Never:** If configured, it will keep the display off.
- **Contrast:** Allows you to configure the display contrast level. There are eight levels of contrast. The lowest level simplifies viewing at the upper and lower viewing angles and the higher-level simplifies viewing at the front viewing angle.
- **Update Interval:** Allows you to configure how often the display information will be updated.
  - **Use log interval:** If configured, it will cause the display information to be updated at each log range.

- **Interval:** Allows you to set a display update range in seconds that is smaller than the log range. This way, the input channels will be read and will update the display at this range. The minimum range is 1 second; the maximum range is 18 hours.

## CLOCK

- **Date/Time:** Allows you to set the date/time used to set the device clock.
- **GMT:** Allows you to configure the GMT of the place where the device will be used (preferably during first use). By default, **Accsense Wi-Fi Pro** is set to GMT 0.
- **Date/Time Format:** Allows you to configure the clock format to 24 hours or AM/PM.

## ANALOG CHANNELS PARAMETERS

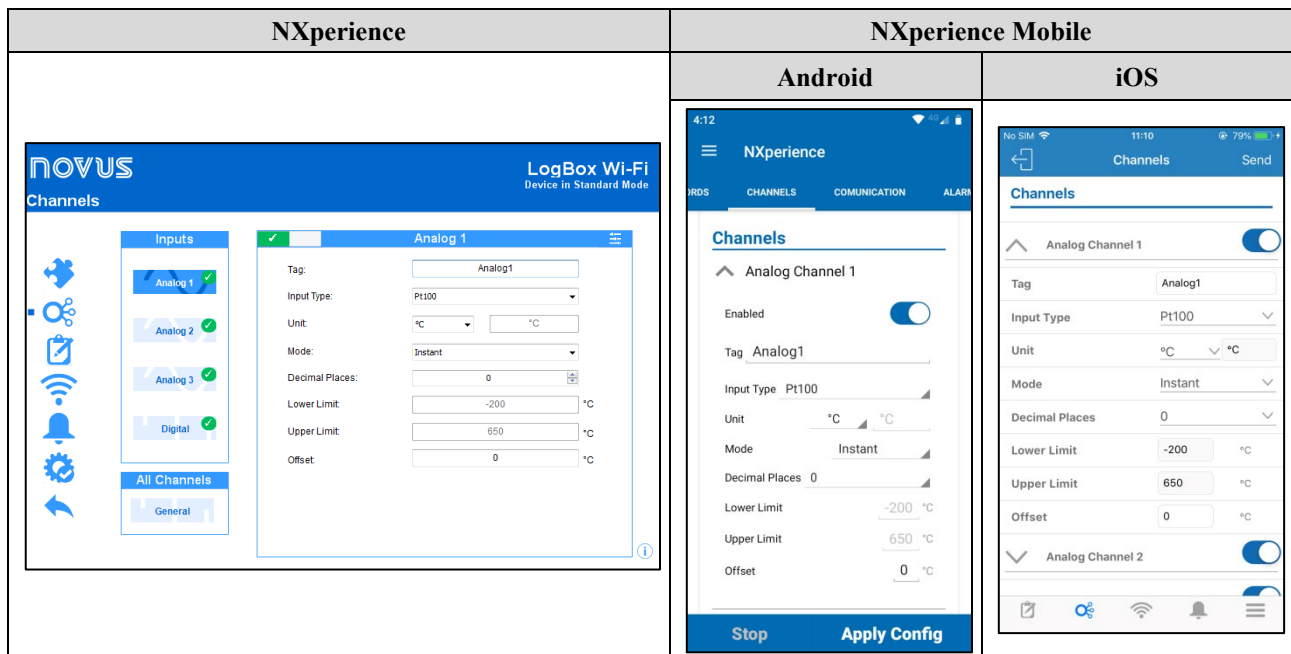

Figure 14 – Analog Channel Screen

- **Tag:** Allows you to set a name, which will be used as channel identification during a download, for the digital channel. The field accepts up to 16 characters.
- **Input Type:** Allows you to configure the type of sensor to be used in each analog channel.
- **Unit:** Allows you to configure the unit for each analog channel. In the case of temperature sensors, it is possible to select the units °C or °F. For other sensors, it is possible to describe the unit with up to eight characters.
- **Mode:** Allows you to configure the operation mode to use for each analog channel. If "Instant" mode is selected, the channel is read, and the value will be logged at each log range. If "Average" mode is selected, the device will take 10 channel readings within the log range and at each log range the average of these 10 readings will be logged.
- **Decimal Places:** Allows you to configure the number of decimal places of each analog channel. Temperature Sensors can be configured to show up to one decimal place. Other sensor types can be configured to show up to two decimal places.
- **Lower Limit:** If the sensor configured for the channel is a temperature or internal diagnostic sensor, the lower limit will be filled by the software with the sensor's lower limit. If the sensor configured for

the channel is of the linear sensor type (mV, V, or mA), it will be necessary to fill in the desired value to represent the minimum value of the chosen sensor.

- **Upper Limit:** If the sensor configured for the channel is a temperature or internal diagnostic sensor, the upper limit will be filled by the software with the sensor's upper limit. If the sensor configured for the channel is of the linear sensor type (mV, V, or mA), it will be necessary to fill in the desired value to represent the maximum value of the chosen sensor.
- **Offset:** Allows you to make small adjustments to the readings of each channel. The configured Offset will be added to all readings performed on the configured channel.

## CUSTOM CALIBRATION





The  icon opens the custom calibration screen, which allows you to adjust up to 10 measurement points for each channel. When a custom calibration has been configured, the minimum number of setpoints is two points.

Figure 15 – Customized Calibration Screen

- **Measured:** Displays the device's read value for which a correction is desired. It can be obtained by clicking the "Read Channel" button or manually filled in.
- **Desired:** Shows the user's desired value for the device measured value. It must be filled manually.
- **Read Channel:** Allows you to obtain the device's values during a custom calibration.
- **Add:** Allows you to enter the "Measured" and "Desired" pair in the Custom Calibration table.
- **Modify:** Allows you to modify the "Measured" and "Desired" pair in the Custom Calibration table.
- **Organize** : Allows you to sort the Custom Calibration table.
- **Delete** : Allows you to delete the selected line from the Custom Calibration table.
- **Delete All** : Allows you to clear the entire Custom Calibration table.
- **Apply:** Allows you to apply the custom calibration to the channel being configured.
- **Cancel:** Allows you to cancel the Custom Calibration operation.

## DIGITAL CHANNEL PARAMETERS

### "EVENT LOG" OR "LOGS CONTROL" MODE

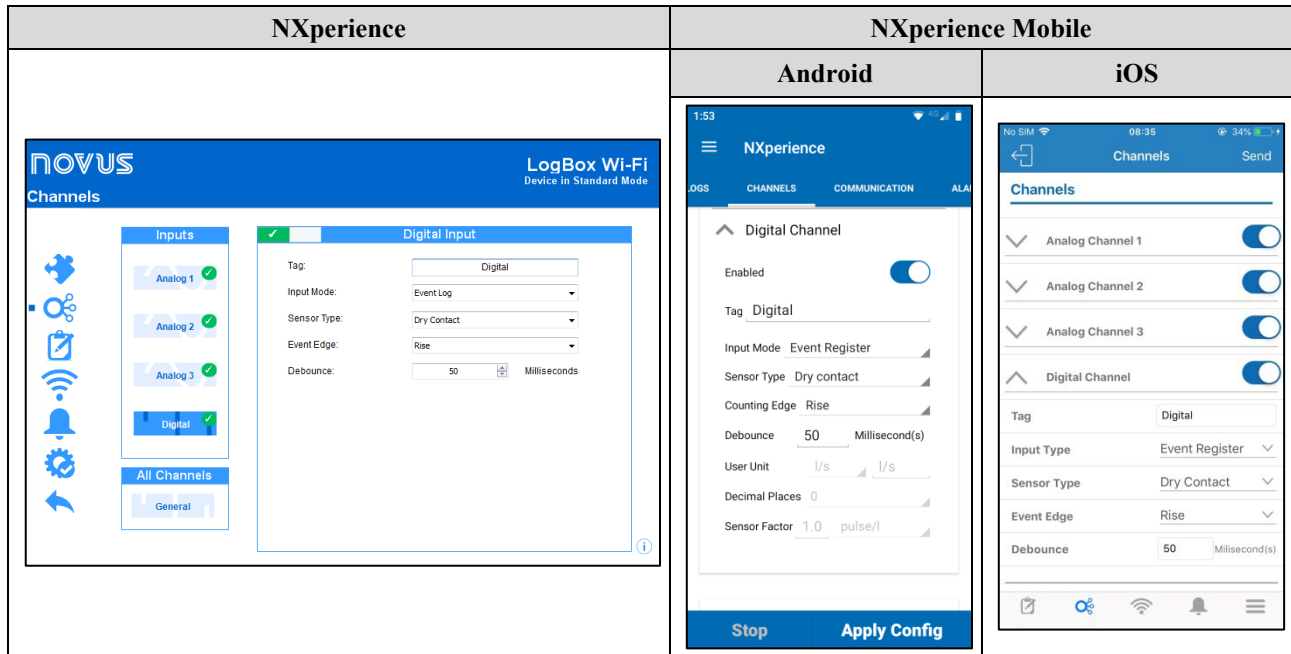

Figure 16 – Digital Input Screen: Event Log Mode

- **Tag:** Allows you to set a name, which will be used as channel identification during a download, for the digital channel. The field accepts up to 16 characters.
- **Input Mode:** Allows you to select the digital input mode, which has the options "Pulse Count", "Event Log", or "Logs Control". If the "Logs Control" mode is selected, the "By Digital Input" mode must be selected in the "Start Mode" and "End Mode" parameters in the "Data Logs" screen. Otherwise, the configuration will have no effect.
- **Sensor Type:** Allows you to configure the sensor type to be connected to the digital input: PNP, NPN, or Dry Contact.
- **Event Edge:** Allows you to configure the desired event edge. This way, the device will log events whenever the configured edge is detected at the digital input. In the "Event Log" mode, you can configure so that the logs are made during the Rising, Falling, or Both edges. In the "Logs Control" mode, it is possible to select to control logs at the Rising, Falling, or Both edges, logging at logic level '1' or logical level '0'.
- **Debounce:** It will be necessary to configure a debounce time for edge detection. Debounce refers to the sensor stabilization time – the minimum time at which the sensor must remain at the logical level of interest so that the detected edge is considered valid. The minimum configurable debounce time is 50 milliseconds; the maximum are 6 seconds. The device will only register the event after the end of the debounce time.

## CHANNELS GENERAL PARAMETERS

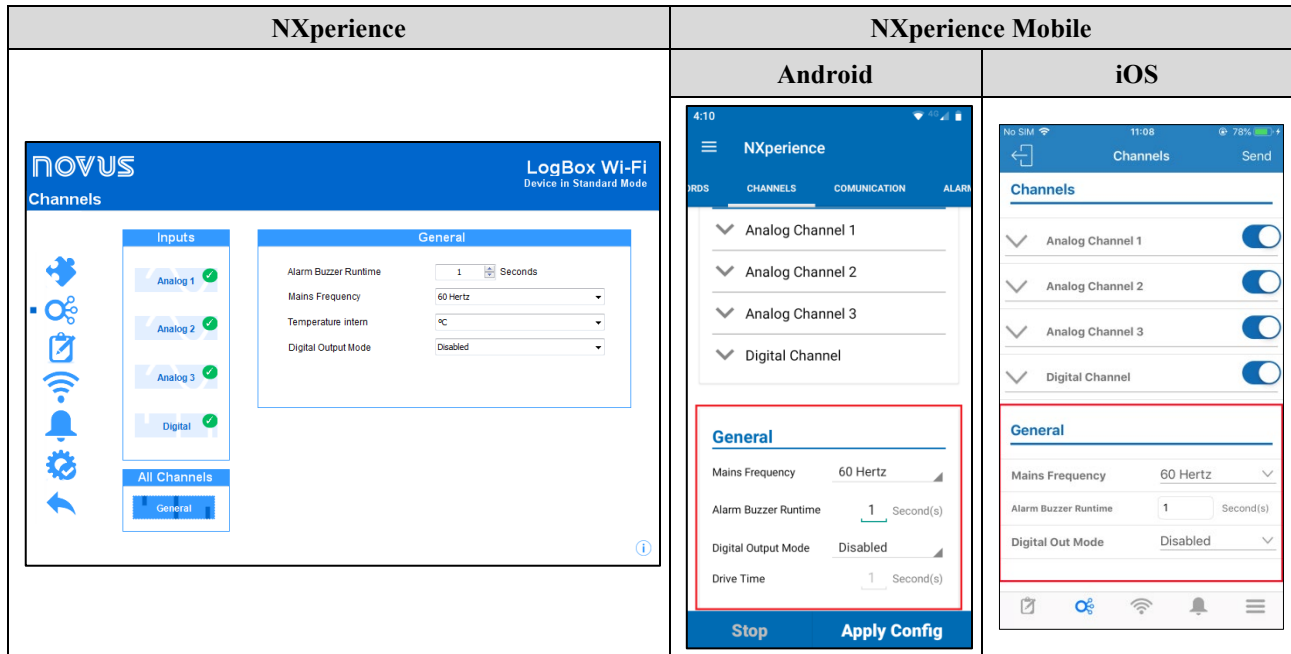

Figure 17 – Digital Input Screen: General Configuration

- **Alarm Buzzer Runtime:** Allows you to set the buzzer runtime for each time the device enters an alarm situation. The configuration will be performed in seconds, from 0 to 65000 s, where 0 means that the buzzer should not be triggered.
- **Mains Frequency:** Allows you to set the local power grid frequency (50 Hz or 60 Hz) for the device to perform better.
- **Intern Temperature:** Allows you to set the unit of measure in which the internal temperature will be displayed.
- **Digital Output Mode:** Allows you to configure the digital output mode, which can be configured as Disabled, Auxiliary Electronic Switch, or Alarm Status.
  - **Auxiliary Electronic Switch:** Allows you to control the power supply of external instruments during analog channel readings.
    - **Drive Time:** Allows you to configure, in seconds, how long before each acquisition the digital output must be triggered. The minimum configurable time is 0 seconds; the maximum time is 15 minutes (900 seconds). If equal to 0, the Auxiliary Electronic Switch will be enabled at the exact moment of an acquisition. If greater than or equal to the lowest acquisition range, the Auxiliary Electronic Switch will remain continuously enabled.
  - **Alarm Status:** In this mode, the digital output will follow the current and general alarm status. If any channel is in an alarm situation, the Digital Output will be enabled. If no channel is set to alarm, the Digital Output will be disabled.

## LOG CONFIGURATION

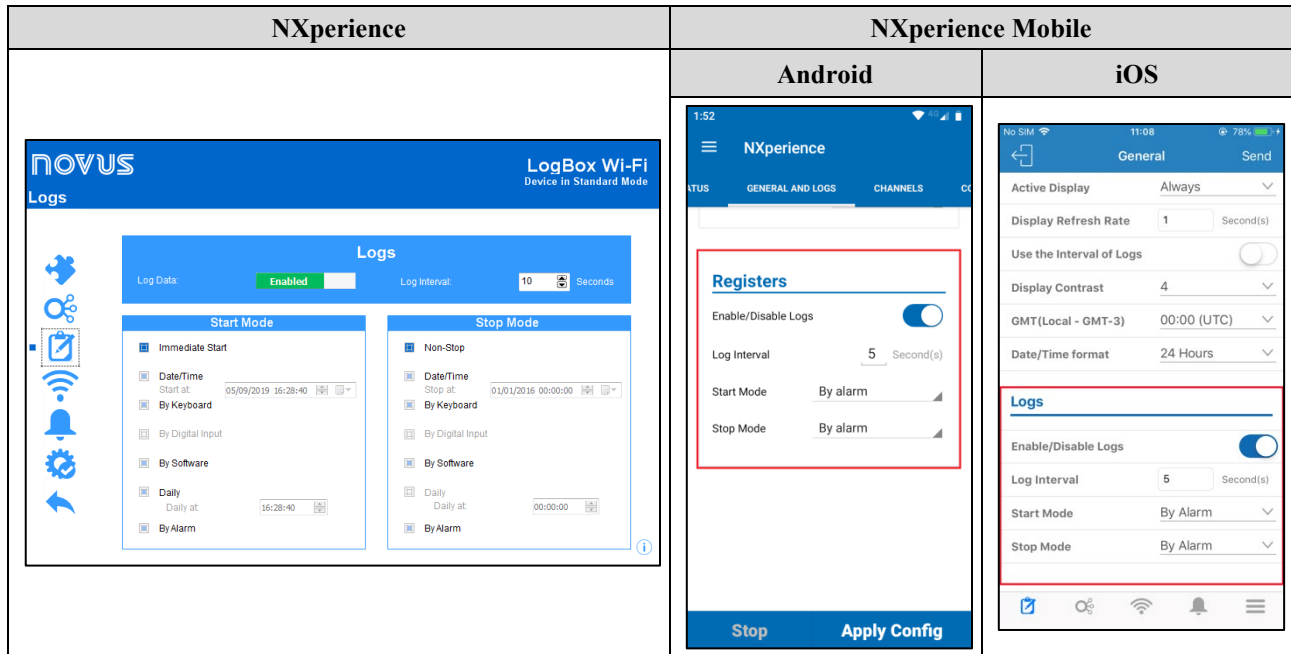

Figure 18 – Log Screen

### LOGS

- **Log Data:** Enables or disables the device data logging.
- **Log Interval:** Allows you to select the frequency, in seconds, with which an acquisition must be made and logged in the memory.
  - **Minimum Range:**
    - 1 second - if no channel is configured to operate on average
    - 10 seconds - if a channel is configured to operate on average
  - **Maximum Range:** 18 hours.

### START MODE

- **Immediate Start:** Allows logs to be started shortly after the device is reconfigured.
- **Date/Time:** Allows you to set the date/time when the logs are to be started.
- **By Keyboard:** In a screen in the display, you can change the logs status to *enabled*, which start the logs (in case they had not been started yet).
- **By Digital Input:** Allows logs to be initiated from the digital input. This parameter is available if the digital input is enabled and configured in the "Logs Control" mode. This way, the logs will be started the moment the digital input is triggered. The log edge shall be configured in the digital input parameters.
- **By Software:** Allows logs to be started using an **NXperience** command.
- **Daily:** It allows the logs to be started every day and at the configured time. The "Daily" log start mode also requires "Daily" log end mode.
- **By Alarm:** Allows logs to be started from a specific alarm.

## STOP MODE

- **Non-Stop:** Allows logs to continue indefinitely. When filling the memory, the oldest data will be deleted so that the most recent ones can be saved.
- **Date/Time:** Allows you to set the date/time when the logs are to be ended.
- **By Keyboard:** Allows you to change logs status to *disabled* on a screen in the display by instantly closing the logs.
- **By Digital Input:** Allows logs to be paused from the digital input. This parameter is available if the digital input is enabled and configured in the "Logs Control" mode. This way, the logs will be paused the moment the digital input is triggered. The log edge shall be configured in the digital input parameters.
- **By Software:** Allows logs to be ended using an **NXperience** command.
- **Daily:** It allows the logs to be ended every day and at the configured time. The "Daily" log start mode also requires "Daily" log end mode.
- **By Alarm:** Allows logs to be stopped from a specific alarm.

The combinations allowed for starting and ending logs are as follows:

START MODE	STOP MODE
Immediate	Non-Stop or Date/Time or Keyboard or Software or Alarm
Date/Time	Non-Stop or Date/Time or Keyboard or Software or Alarm
Digital Input	Non-Stop or Digital Input
Keyboard	Non-Stop or Keyboard
Software	Non-Stop or Software
Daily	Daily
Alarm	Non-Stop or Alarm

Table 3 – Logs End Modes

## COMMUNICATION PARAMETERS

### WI-FI CONFIGURATION

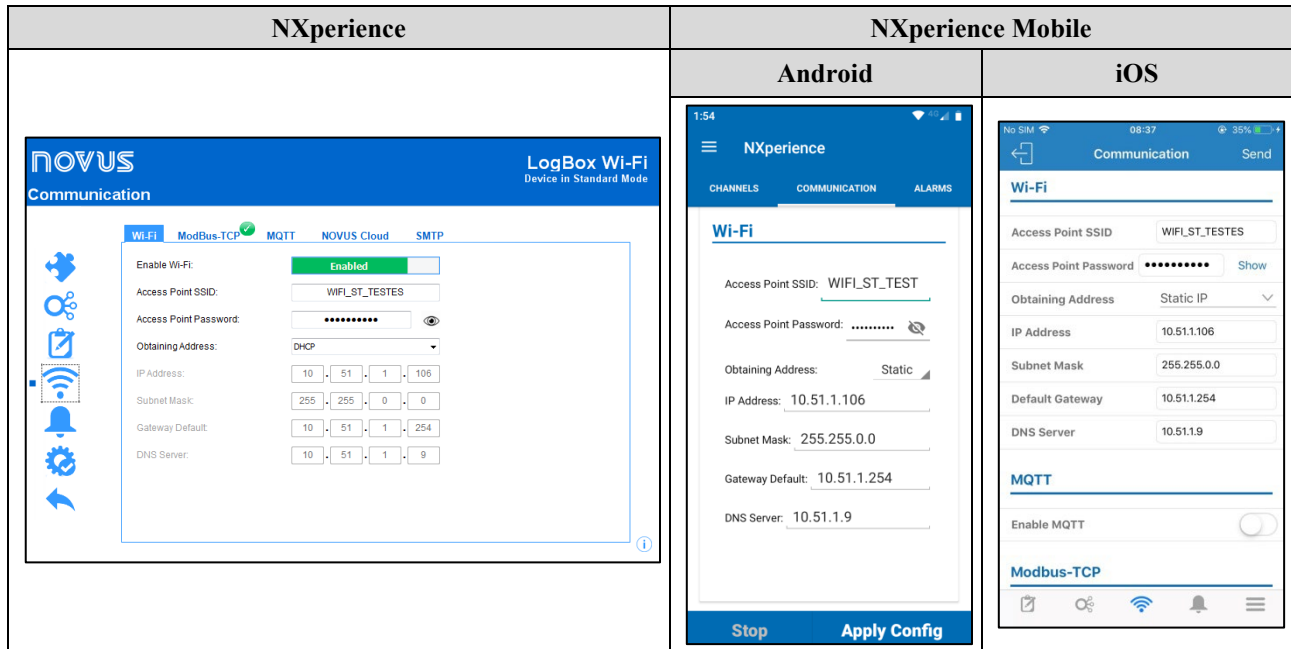

Figure 19 – Configuration Screen

- **Enable Wi-Fi:** Allows you to enable or disable this communication interface. When disabled, the MQTT parameters will remain disabled. When the **Accsense Wi-Fi Pro** does not have an external power supply and is running on batteries, this interface will be automatically disabled.
- **Access Point SSID:** Allows you to enter the name of the Wi-Fi network to which **Accsense Wi-Fi Pro** will try to connect to. The field accepts up to 32 alphanumeric characters.
- **Access Point Password:** Allows you to enter the Wi-Fi network password to which **Accsense Wi-Fi Pro** will try to connect to. The field accepts up to 40 alphanumeric characters.
- **Obtaining Address:** Allows you to determine how **Accsense Wi-Fi Pro** will try to acquire an IP: DHCP (*Dynamic Host Configuration Protocol*), protocol that allows the device's IP (*Internet Protocol*) to be assigned by the network server, or Static, which allows the user to set the IP address, subnet mask, and default gateway for the connection. In this case, you can also set the DNS (*Domain Name System*).
- **IP Address:** Refers a device identification (computer, printer, etc.) on a local or public network. Each computer or device on the Internet or on an internal network has a unique IP. This is a required field when "Obtaining Address" is marked as "Static".
- **Subnet Mask:** Also known as *subnet mask* or *netmask*, it allows you to divide a specific network into smaller subnets, making it more effective to use a particular IP address space. This is a required field when "Obtaining Address" is marked as "Static".
- **Gateway Default:** Refers to the device address on the network that connects your computers to the internet. This is a required field when "Obtaining Address" is marked as "Static".

- **DNS Server:** Refers to a hierarchical and distributed name management system for computers, services, or any resource connected to the Internet or a private network. This is an optional field when "Obtaining Address" is marked as "Static".

## SETTING UP ACCSENSE CLOUD CONNECTION PARAMETERS



Figure 20 – Configuration Screen: MQTT

- **Enable MQTT:** Enables or disables data submission by MQTT protocol. When the **Accsense Wi-Fi Pro** does not have an active external power supply and is running on batteries, the Wi-Fi interface will remain disabled and, therefore, sending data through this protocol as well.
- **Broker User:** Allows you to enter the registered user's login on the Broker. The field accepts up to 40 characters. If the field is empty, the connection will be made in anonymous mode.
- **Broker Password:** Allows you to enter the registered user's password on the Broker. The field accepts up to 40 characters. If the field is empty, the connection will be made in anonymous mode.
- **Broker URL or IP:** Allows you to enter the Broker address, which can be a URL (*Uniform Resource Locator*) or an IP. The field accepts up to 60 characters.
- **Time Format:** Allows you to choose the time format to display: DateTime or Unix Timestamp. Changes the sent date/time format of the JSON frame.
- **Boolean Format:** Indicates how Boolean variables will be displayed in the JSON frame. For more information, check the [Boolean Format](#) section of the [MQTT Protocol](#) chapter.
- **Clean Mode:** When enabled, it indicates to the Broker that it is necessary to store only the last data of each topic. By disabling this option, the Broker, if configured, will keep all historical data stored.
- **Write Permissions:** Selects which commands will be available for user writing via MQTT.
- **Publication Topic:** Allows you to view the subscription and publication topic formats.

- **Service Port:** Allows you to define the port number used to connect to the Broker.
  - **QoS:** The "Quality of Service" parameter allows you to select the level of quality of service used to send MQTT messages. Your options are 0, 1, or 2. For more information, check the [QoS](#) section of the [MQTT Protocol](#) chapter.
  - **JSON Format:** Changes the formatting of the JSON frame as required by the supervisor. For more information, check the [JSON Format](#) section of the [MQTT Protocol](#) chapter.
  - **Security:** Allows you define the security protocol and data encryption to be used by the MQTT Broker.
    - **None:** None security measures will be used.
    - **TLS V1.2 – CA Only:** If this option is selected, the Broker will use the Transport Layer Security (TLS) 1.2 protocol, which requires a TLS certificate recognized by a certification authority (CA), to ensure the privacy and integrity of the data.
    - **TLS V1.2 – Self Signed:** If this option is selected, the Broker will use the Transport Layer Security (TLS) 1.2 protocol, which, in addition to the TLS certificate recognized by a certification authority (CA), also requires authentication of the client certificate and its private key to ensure privacy and integrity of the data.
- Note:** CA certificate, client certificate and private key files are accepted in .pem and .der formats only.

## ALARM CONFIGURATION



NXperience	NXperience Mobile	
	Android	iOS
	Clicking on the alarm button will enable or disable it.	
		
	Clicking on the alarm will allow you to configure it.	

Figure 21 – Alarms screen

- **Tag:** Allows you to set a name, which will be used as alarm identification, for each alarm enabled. The field allows up to 16 characters.
- **Operation:** Allows you to select the operation to be performed by the alarm enabled. This feature has three parameters, which allow you to select the channels or setpoint to be analyzed and the operation to be performed (see chapter [Alarms](#)).
  - **Setpoint:** Allows you to set the value to be exceeded for the channel to satisfy the alarm situation.
  - **Hysteresis:** Allows you to set the barrier to be exceeded for the channel to exit the alarm situation.
  - **Range:** Allows you to set the range that will satisfy the alarm situation.

	<p>When configuring the alarm for a digital input that is configured for "Event Log" or "Logs Control" mode, you can only use the '=' comparison with Setpoints '0' or '1', since the alarm will be used to compare with the logic level of the channel. Also, it is important to note that if configured for "Event Edge: Rise" or "Event Edge: Fall", the alarm may never enter or never leave the alarm state. Thus, for the alarm to operate correctly, it is recommended to use the "Event Edge: Both" option.</p>
-----------------------------------------------------------------------------------	-------------------------------------------------------------------------------------------------------------------------------------------------------------------------------------------------------------------------------------------------------------------------------------------------------------------------------------------------------------------------------------------------------------------------------------------------------------------------------------------------------------------------

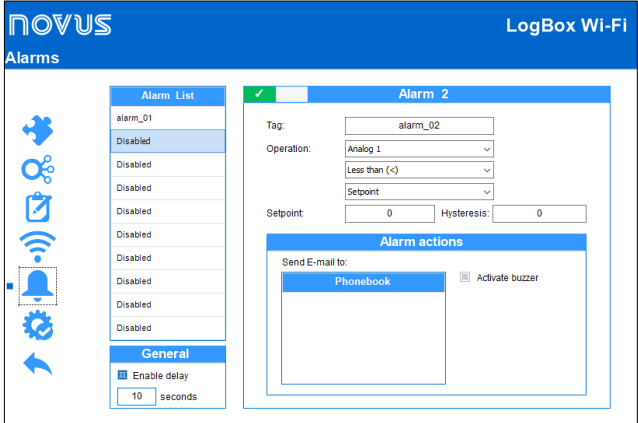
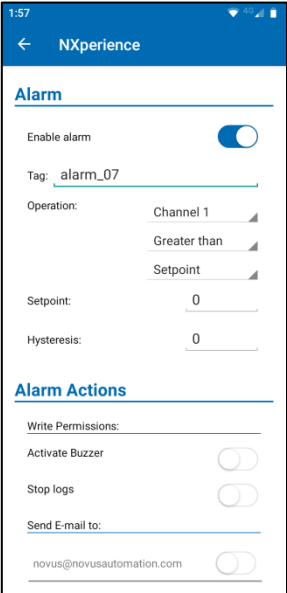
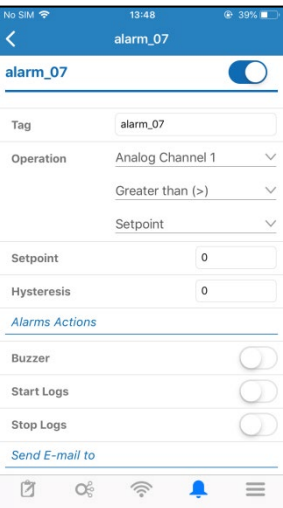
- **General:** Allows you to enable or disable the alarm delay option.
  - **Enable delay:** Allows you to enable the delay of configured alarms. Once enabled, the device will only consider an alarm if the setpoint is exceeded and maintained for a timer longer than the configured delay.
  - **Configure seconds:** Allows you to configure the delay period to be considered. Maximum value: 3600 seconds.

NXperience	NXperience Mobile	
	Android	iOS
		

Figure 22 – Alarm actions

- **Alarm Actions:** Allows you to select the actions to be taken whenever the configured alarm enters an alarm situation.
  - **Send E-mail to:** Allows you to select the contacts that should receive this alarm notification (see [SMTP Protocol](#) section of the [Configuration Software](#) chapter).
  - **Activate Buzzer:** Allows you to select so that the buzzer is activated whenever the configured alarm goes into alarm.
  - **Start Logs:** If the Log Start Mode is set to "By Alarm", it allows you to start logging every time the alarm goes into alarm. The "Start Logs" and "Stop Logs" actions are mutually exclusive. Once an alarm has been set to start the logs whenever the device enters alarm situation, it will not be possible to use the same alarm to stop them.

- **Stop Logs:** If Log Stop Mode is set to "By Alarm", it allows you to stop logging every time the alarm goes into alarm. The "Start Logs" and "Stop Logs" actions are mutually exclusive. Once an alarm has been set to stop the logs whenever the device enters alarm situation, it will not be possible to use the same alarm to start them.
- **Log while Active:** If the Start Mode and Stop Mode are set to "By Alarm", it allows you to register whenever the configured alarm is set to alarm. If the configured alarm is no longer in alarm, the device will automatically stop logging. If an alarm has been set in the "Start Logs" or "Stop Logs" modes, it will not be possible to set any alarm in the "Log while Active" mode. Unlike the previous modes, which allow only a single alarm to be configured for each action, this mode has many alarms.

## COMPARISON BETWEEN CHANNELS

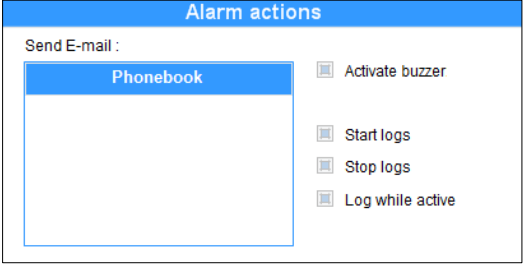
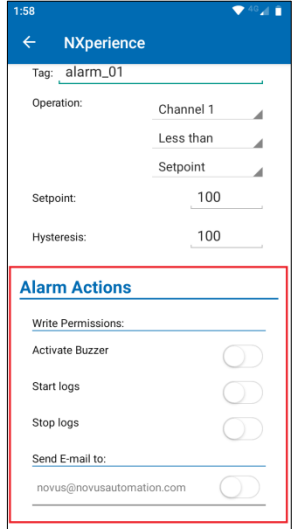
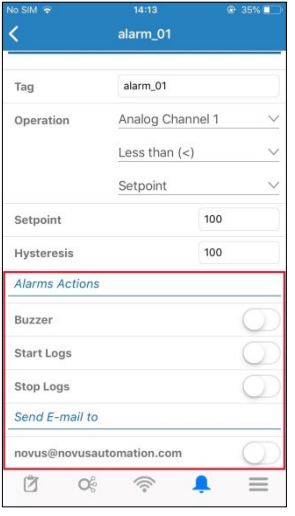
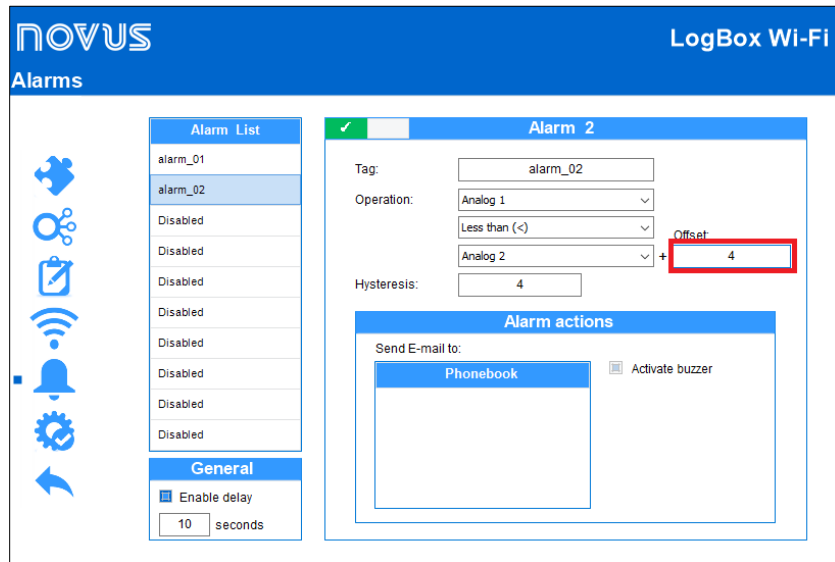

Figure 23 – Comparison between channels

You can create a comparison alarm between two channels. When selecting the operation and channels to be compared, you can add an offset value (corresponding to the parameter highlighted in red) to the second selected channel. Thus, the value of the first channel will be compared to the value of the second channel and the configured offset value.

## DIAGNOSTICS

It is possible to view the **Accsense Wi-Fi Pro** diagnostics tab by clicking the **Diagnostics** button located on the **NXperience** home screen. By clicking on it, the software will monitor some device states. The information update range is 1 second.

## LOGS

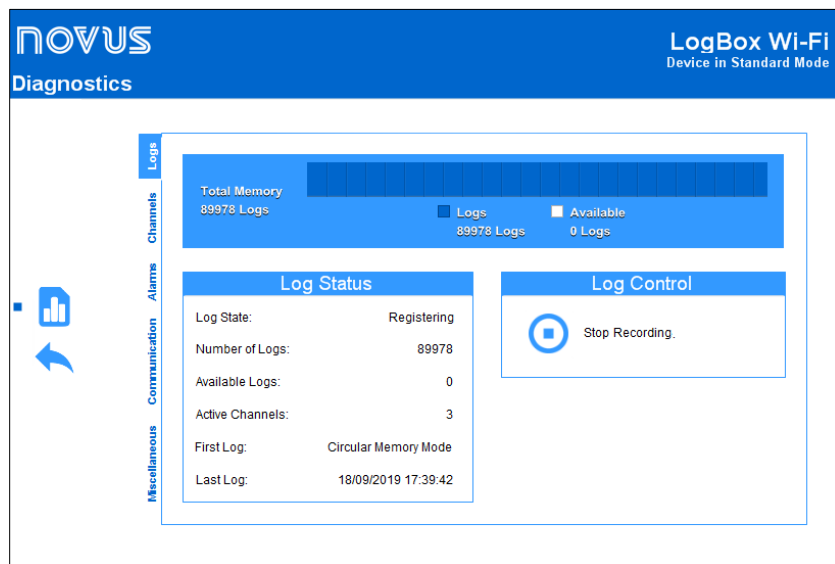

Figure 24 – Diagnostics Screen: Logs

- **Log Status:** Displays information about the log status, such as the number of recorded logs, the available memory, the number of active channels, and the date of the first and last log in the **Accsense Wi-Fi Pro** memory.
- **Log Control:** Allows you to start or pause **Accsense Wi-Fi Pro** data logging. For this option to be active, the "By Software" parameter must be enabled in start and/or end of log mode.

## CHANNELS

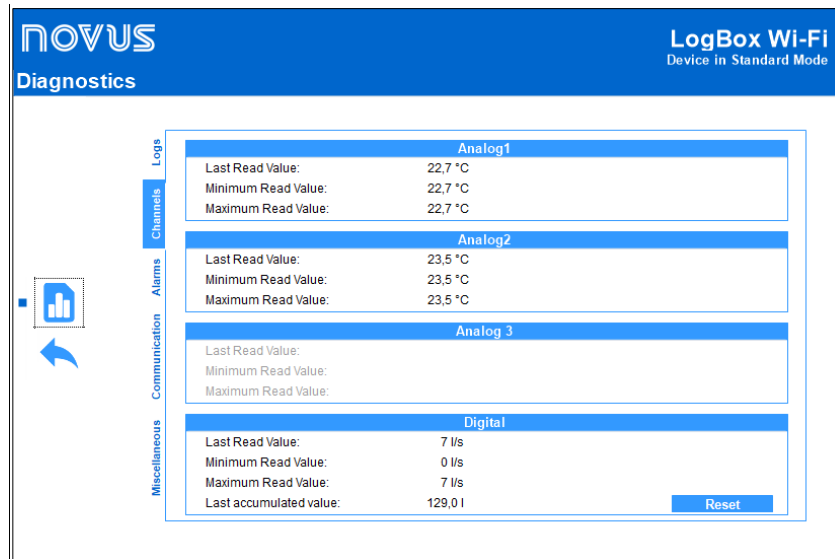

Figure 25 – Diagnostics Screen: Channels

- **Analog Channels and Digital Channel:** Displays information about the acquisitions made by the device on the analog channel sensors and on the digital channel sensor.
  - **Last Read Value:** Displays the value of the last acquisition performed by the device on the corresponding channel sensor. The displayed value may have been updated by a display update frequency and not logged in the memory.
  - **Minimum Read Value:** Displays the minimum read value by the device on the corresponding channel sensor. The displayed value may have been read by a display update frequency and not logged in the memory.
  - **Maximum Read Value:** Displays the maximum value read by the device on the corresponding channel sensor. The displayed value may have been read by a display update frequency and not logged in the memory.
  - **Last Accumulated Value:** For the digital channel, it displays the last accumulated value by the device in Pulse Count mode. Clicking on the **Reset** button allows resetting the accumulator value and restarting the counting.

## ALARMS

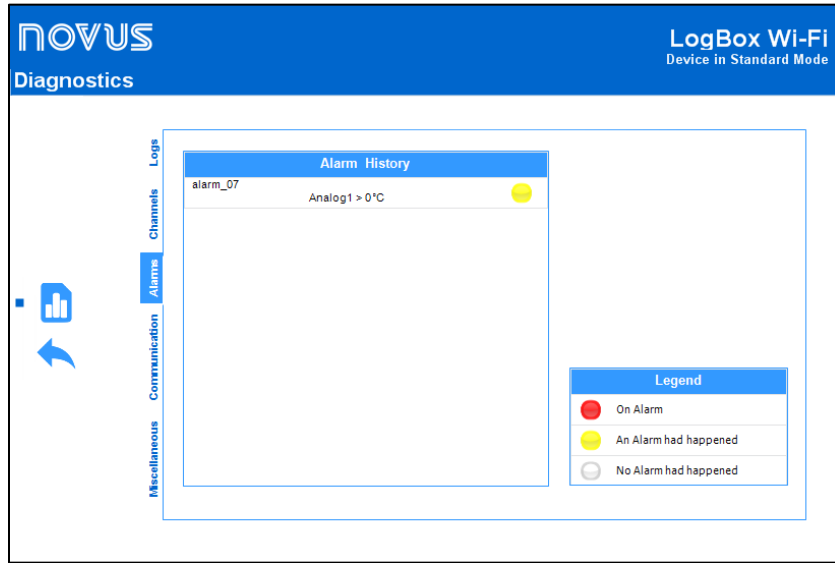

Figure 26 – Diagnostics Screen: Alarms

This tab provides information on the history of enabled and configured alarms for **Accsense Wi-Fi Pro** (see [Alarms Configuration](#) section), its current condition, and a color legend that shows you if the configured alarms are currently in alarm, whether the configured alarm has already entered an alarm situation at some point, or whether the configured alarm has never entered an alarm situation.

## COMMUNICATION

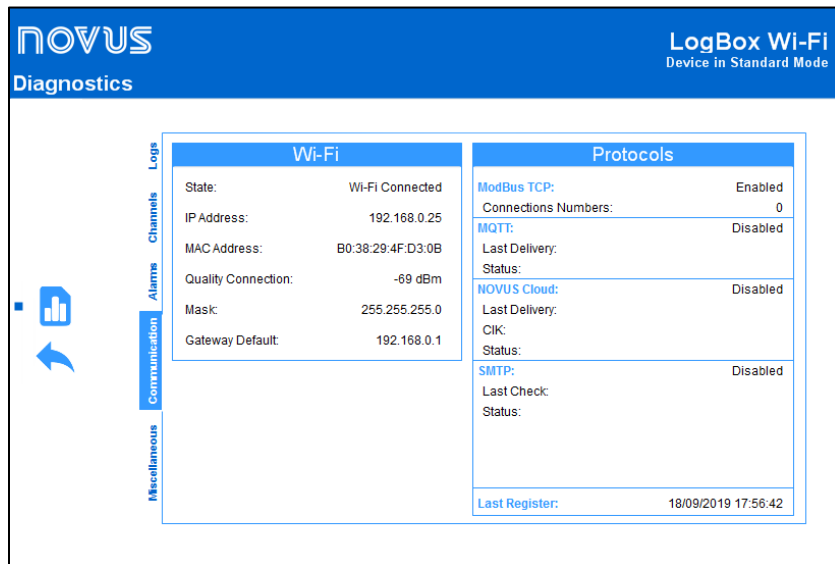

Figure 27 – Diagnostics Screen: Communication

- **Wi-Fi:** Displays information about the device's Wi-Fi connection.
  - **State:** Displays information about the device's current state.
  - **IP Address:** Displays information about the device's IP address.
  - **MAC Address:** Displays information about the device's MAC address.
  - **Quality Connection:** Displays information about the connection quality.

- **Mask:** Displays information about the device's mask.
- **Gateway Default:** Displays information about the device's gateway default.
- **Protocols:** Displays information about the device's protocols
  - **Modbus TCP:** Informs you whether the Modbus-TCP protocol is enabled or disabled and the number of currently active connections.
  - **MQTT:** Informs you whether the MQTT protocol is enabled or disabled and, if enabled, provides data about the last time information was sent and its status.
  - **NOVUS Cloud:** Informs you whether the sharing feature with **NOVUS Cloud** is enabled or disabled, and if enabled, provides information about the last data submission to the cloud and its status.
  - **SMTP:** Informs you whether the SMTP protocol is enabled or disabled and, if enabled, provides information about the last scan performed and its status.
  - **Last Register:** Informs you the date and time of the last log made by the device.

## MISCELLANEOUS

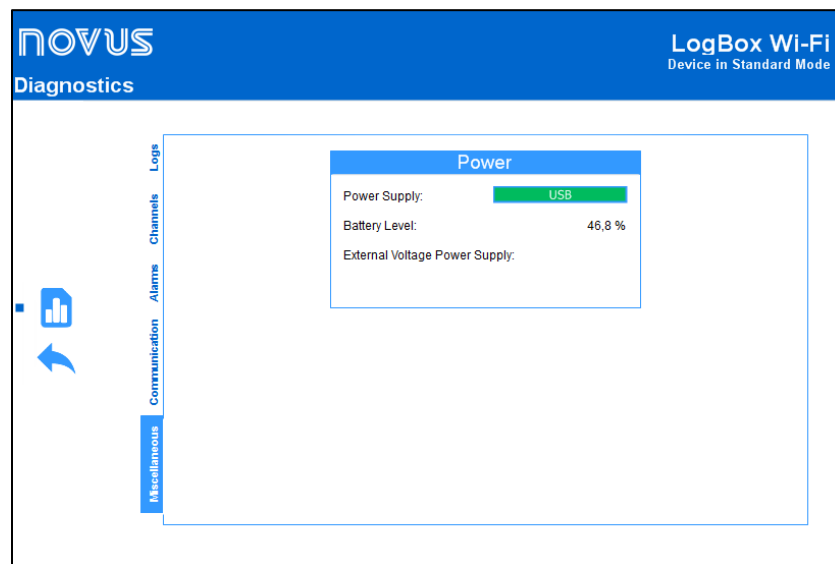

Figure 28 – Diagnostics Screen: Miscellaneous

- **Power:** Displays the device's power information.
  - **Power Supply:** Displays the current power supply of the device.
  - **Battery Level:** Displays the current battery level status. This information is updated in the logs frequency with a minimum frequency of 5 minutes.
  - **External Power Supply Voltage:** Displays the external power supply voltage of the device. This information is updated in the logs frequency with a minimum frequency of 5 minutes.

# ACCSENSE CLOUD WEB SOFTWARE

## CONNECTION TO ACCSENSE CLOUD PORTAL

### USING A WEB BROWSER

To connect to the Accsense cloud to view live and historical data and alarms, open a web browser on your computer and go to:

<http://monitor.accsense.com>

and you will be presented with the login screen:

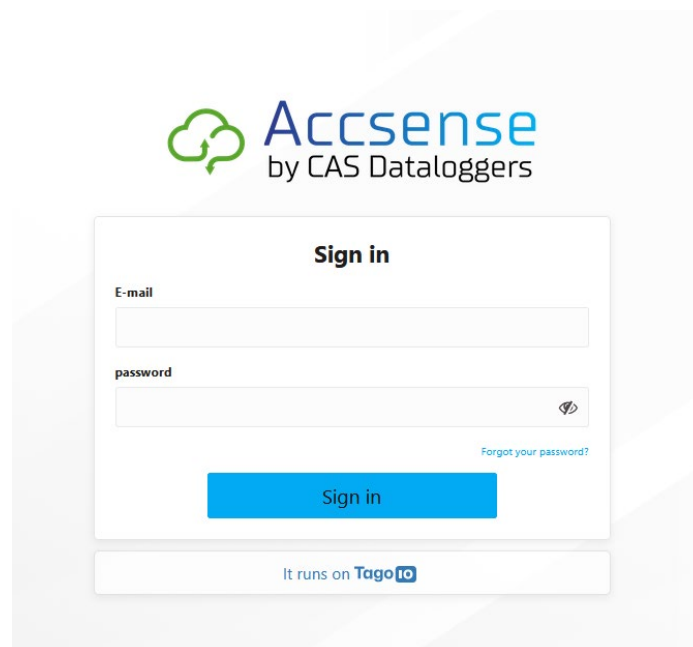

Enter your email and password to sign in. The sign in password is the one that you established in response to the original email to create your account. If you have forgotten your password, click the “Forgot your password?” link and enter your email in the following screen to receive an email to reset your password.

### MOBILE APP

Alternatively, you can access the Accsense Cloud via our mobile app which is available for iOS or Android.

#### IOS

Go to the app store on your iPhone or iPad and search for the Accsense app or [click here](#)

#### ANDROID

Go to the Google Play Store and search for the Accsense app or [click here](#)

Enter your email and password to sign in.

Once you have successfully logged in, you will be presented with the main screen:

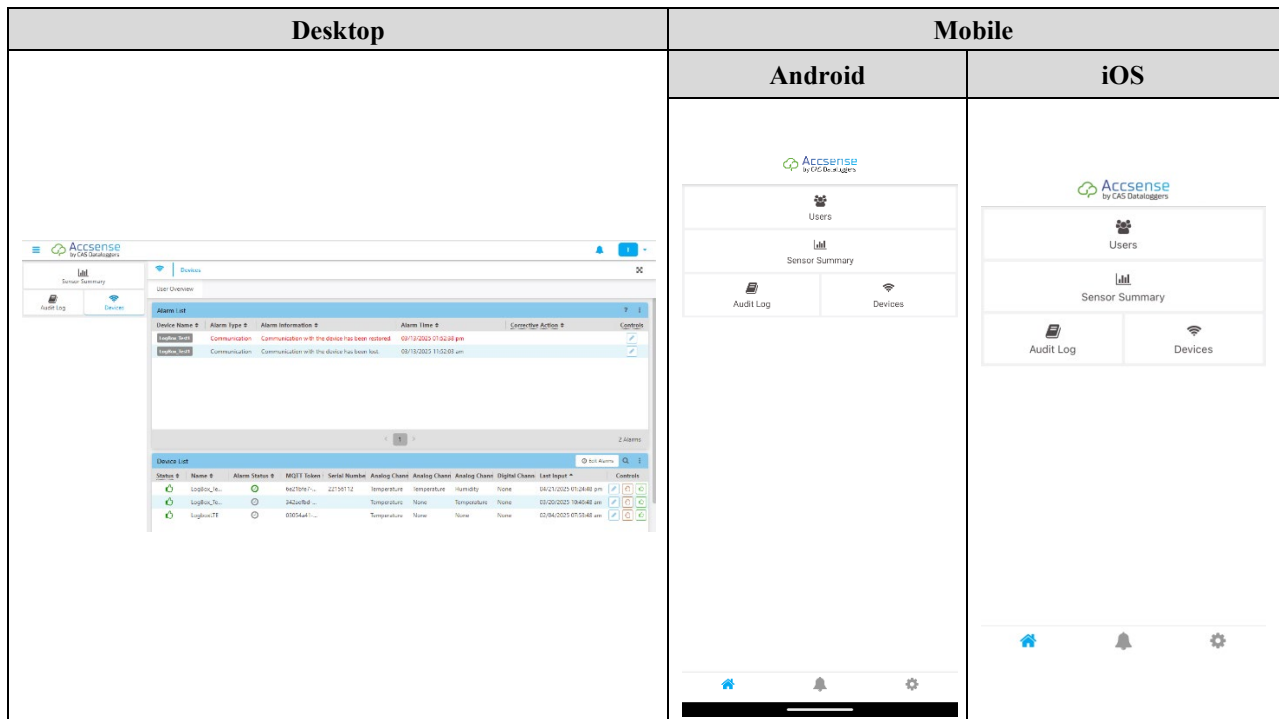
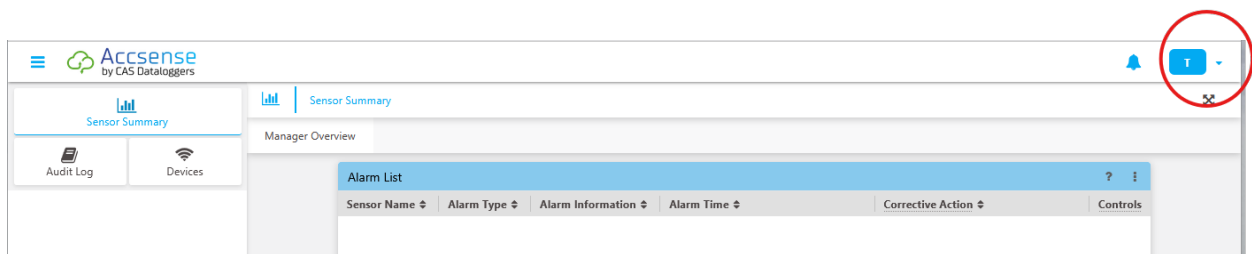

Figure 1 – Main Screen

## ACCOUNTS PREFERENCES – DESKTOP ONLY

To access the User Preferences, click on the icon for your account in the upper right corner and select My Account to open the account settings window.



This window has 3 tabs, one for general settings, one for the visualization settings and one for the security settings.

### GENERAL INFORMATION

The general information tab is only available on the web version of the application and not the mobile versions. It contains the settings for:

Email: The email address that is used for your login, for notifications and for password resets

Name: Your user name which is displayed for entries in the audit log

Phone: The phone number that is uses for SMS and voice notifications

Company: Your company name

Time zone: This is the value that is used to adjust the time for the data displays on the web site and for notifications.

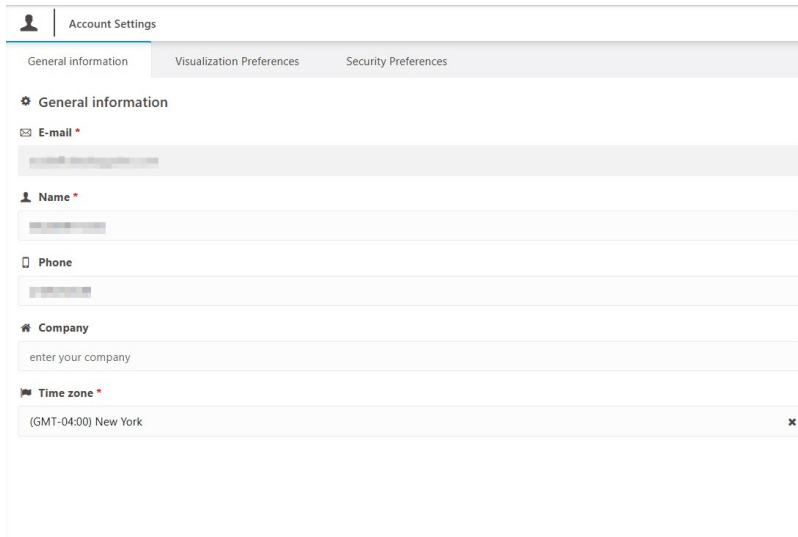

The screenshot shows the 'Account Settings' page with the 'General information' tab selected. The page contains several input fields: 'E-mail' with a placeholder 'example@domain.com', 'Name' with a placeholder 'John Doe', 'Phone' with a placeholder '1234567890', 'Company' with a placeholder 'enter your company', and 'Time zone' with a dropdown menu showing '(GMT-04:00) New York'.

## VISUALIZATION PREFERENCES

The visualization preferences tab is only available on the web version of the application and not the mobile versions. This window contains the settings for:

Language: English, French, Portugese or Spanish

Date Format: MM/DD/YYYY, DD/MM/YYYY or YYYY-MM-DD

Decimal Separator: “.” or “,”

Time Format: 12 or 24 hour

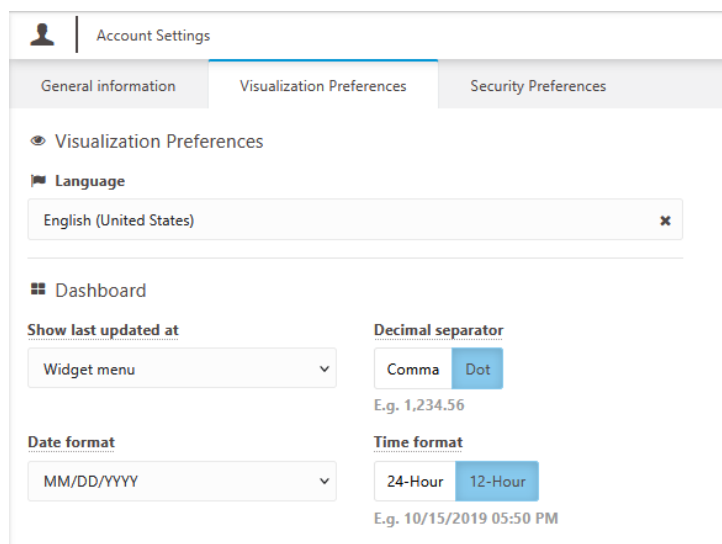

The screenshot shows the 'Account Settings' page with the 'Visualization Preferences' tab selected. The page contains several settings: 'Language' with a dropdown menu showing 'English (United States)', 'Dashboard' section with 'Show last updated at' set to 'Widget menu' and 'Decimal separator' set to 'Dot' (with 'Comma' also visible), 'Date format' set to 'MM/DD/YYYY', and 'Time format' set to '12-Hour' (with '24-Hour' also visible). Examples of the formats are provided: 'E.g. 1,234.56' for decimal separator and 'E.g. 10/15/2019 05:50 PM' for time format.

## SECURITY PREFERENCES

The security preferences tab is only available on the web version of the application and not the mobile versions. This screen allows you to change your password or delete your account.

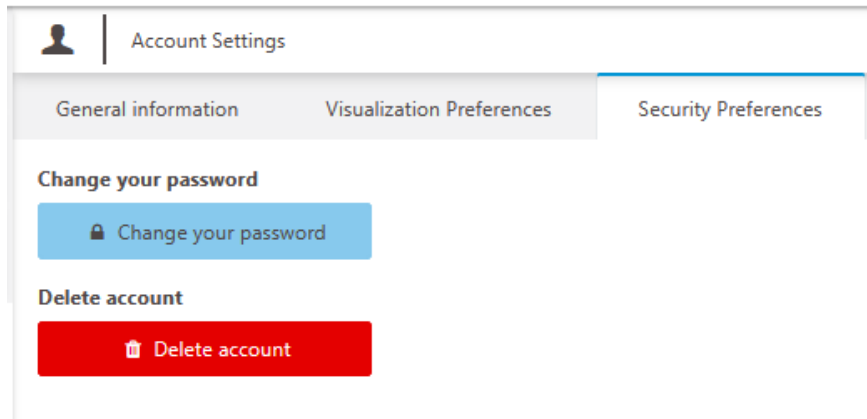

## USERS

Clicking the Users button in the list of items on the left of the screen will open the user settings window. The **Overview** tab will show the current list of users for your account:

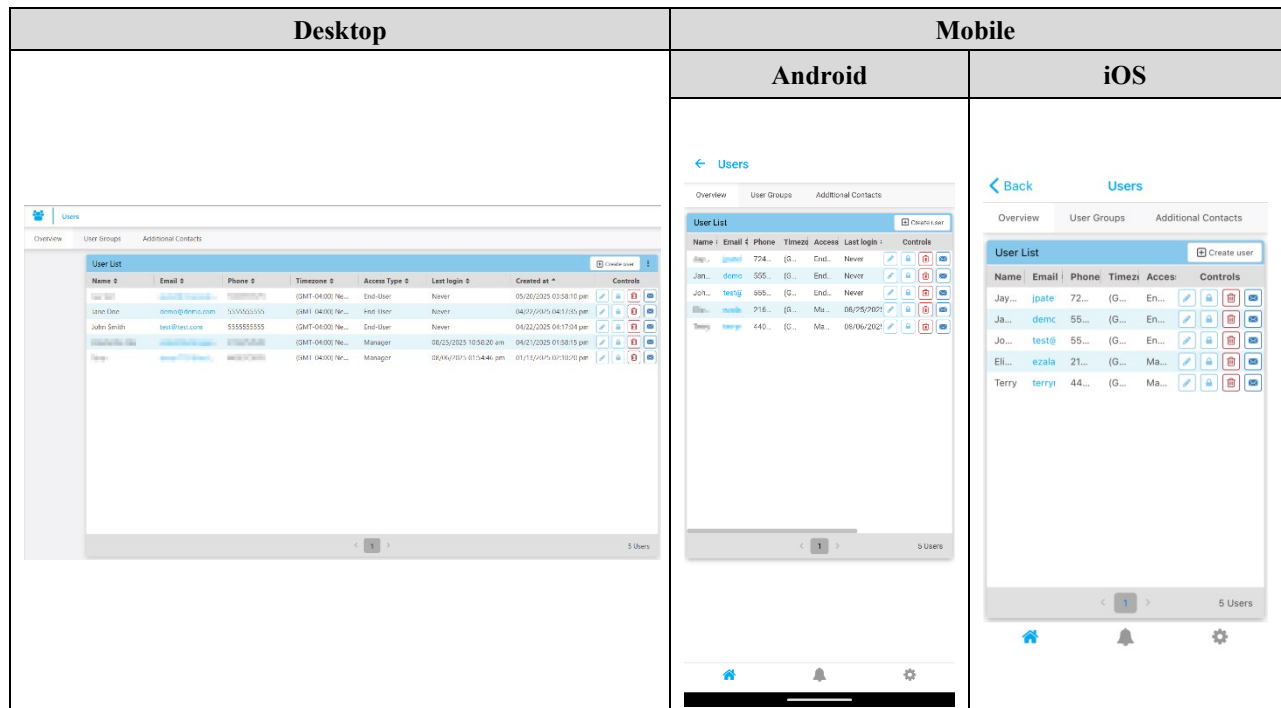

Figure 2 – User Settings Overview

Use the **Create user** button in the upper right corner to add users to your organization. After clicking this button, a screen will pop up to enter the information for the new user:

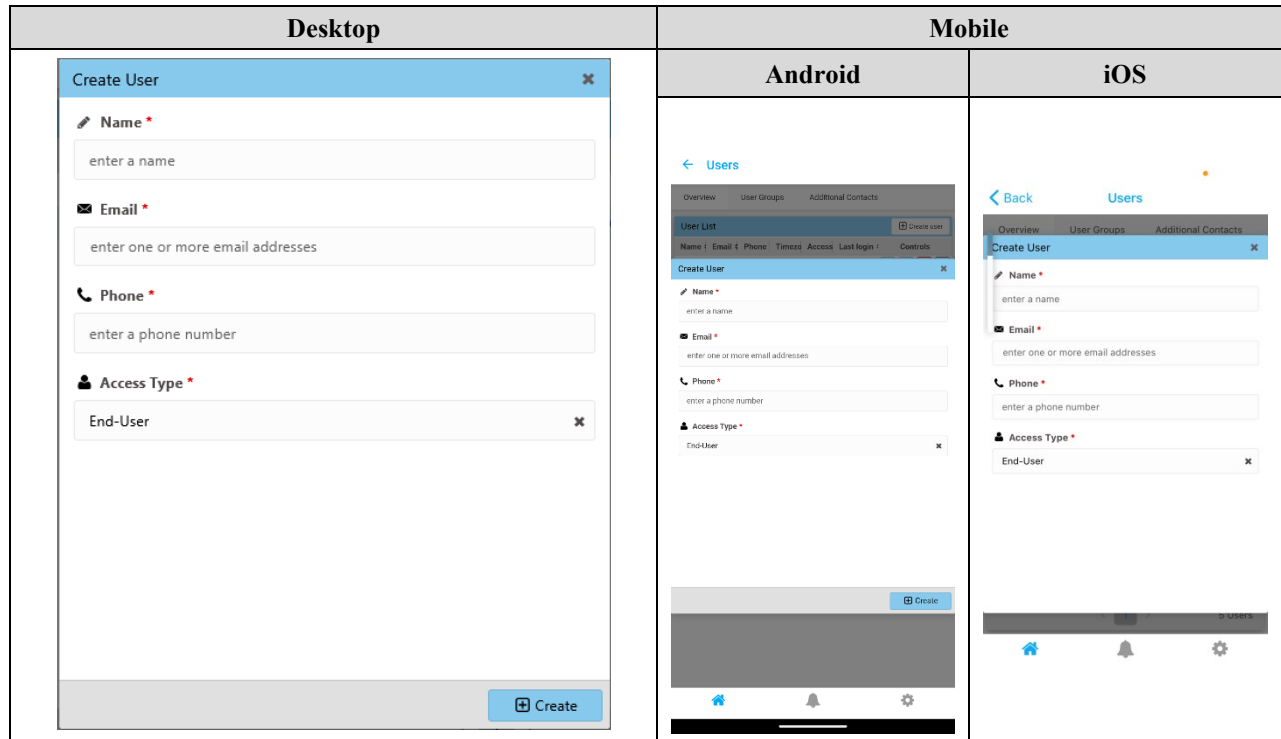

Figure 3 – Creating A User

Name: Your user name which is displayed for entries in the audit log

Email: The email address that is used for your login, for notifications and for password resets

Phone: The phone number that is used for SMS and voice notifications

Access Type: Manager will have full access to modify settings and view data or End-User which can only view data and acknowledge alarms.

Click the **Create** button at the bottom to send the email invitation to the user to finish creation of their account.

On the main User List screen, there are 4 icons to the right of each user that allow you to change their account settings:

Click the **Pencil** icon to edit the user's information including name and phone number.

Click the **Padlock** icon to change the user's password.

Click the **Trash** Can icon to delete the user's account

Click the **Letter** icon to resend the email invitation.

The User Groups tab will show any groups that you have created to be used in custom lists.

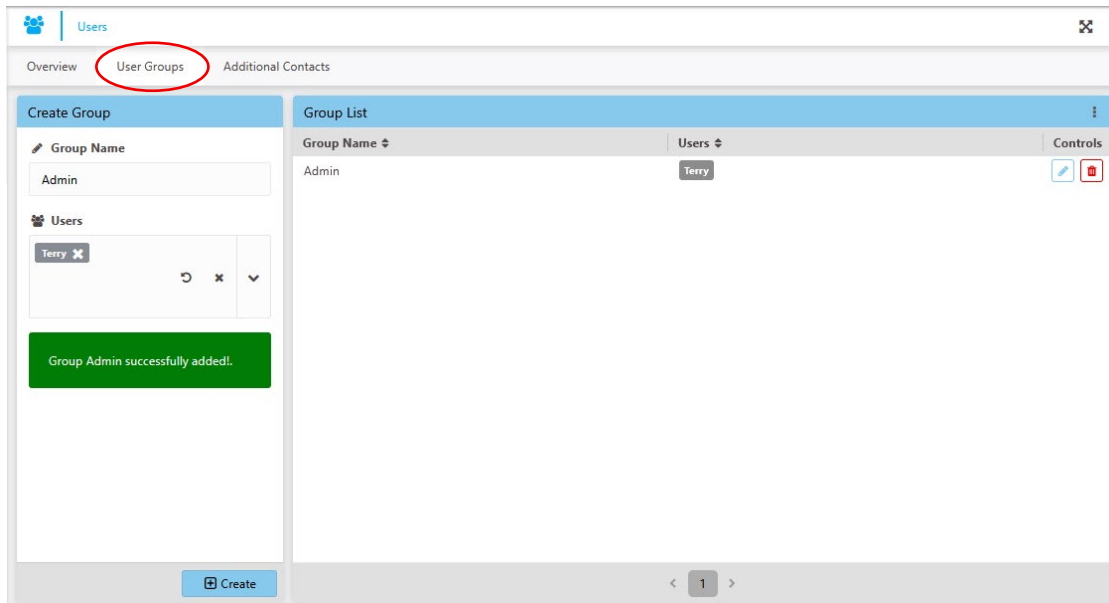

Here we have created an “Admin” group to be used later on for notification of communications loss alarms.

The **Additional Contacts** tab is used to create other users that can receive notifications but who don’t have a regular account to log into the systems. For example, you may want to have an IT person or service technician receive notifications for communications alarms or temperature alarms but which don’t require regular access to the system.

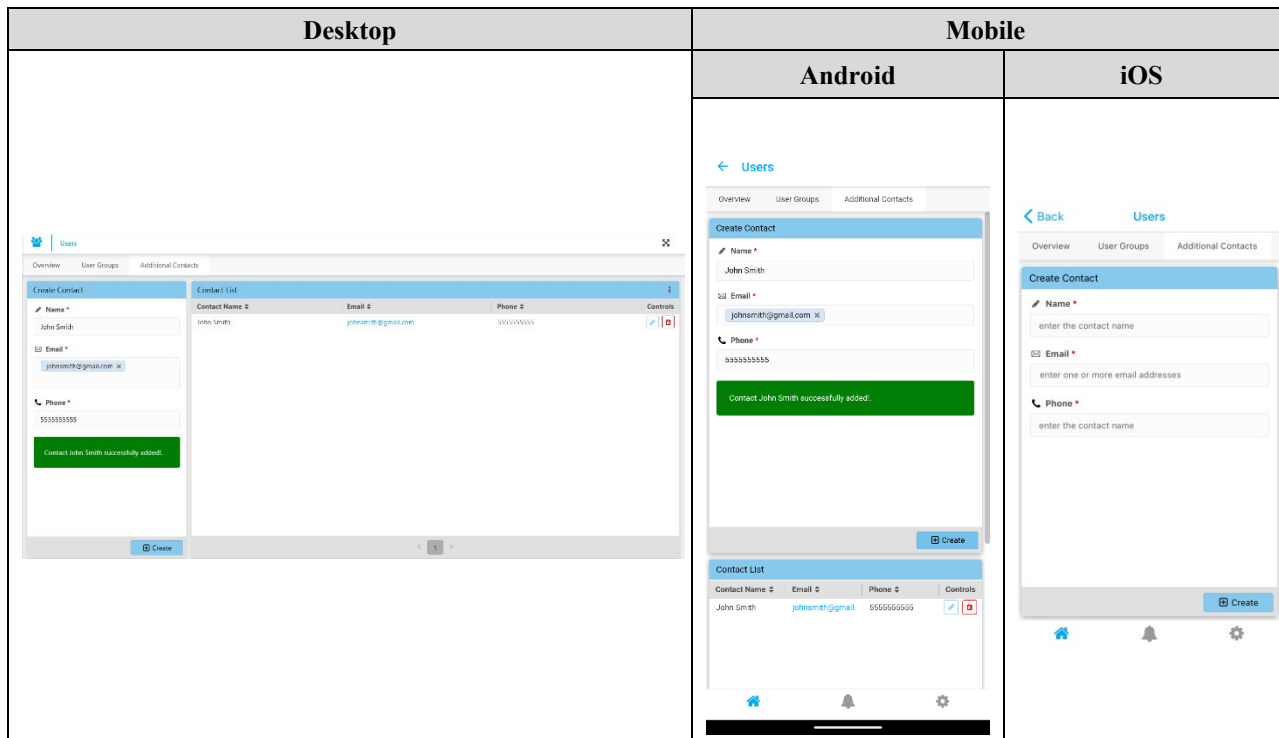

Figure 4 – Creating Additional Contact

## SENSOR SUMMARY

The sensor summary provides an overview of all of the information for the sensors currently configured for your account.

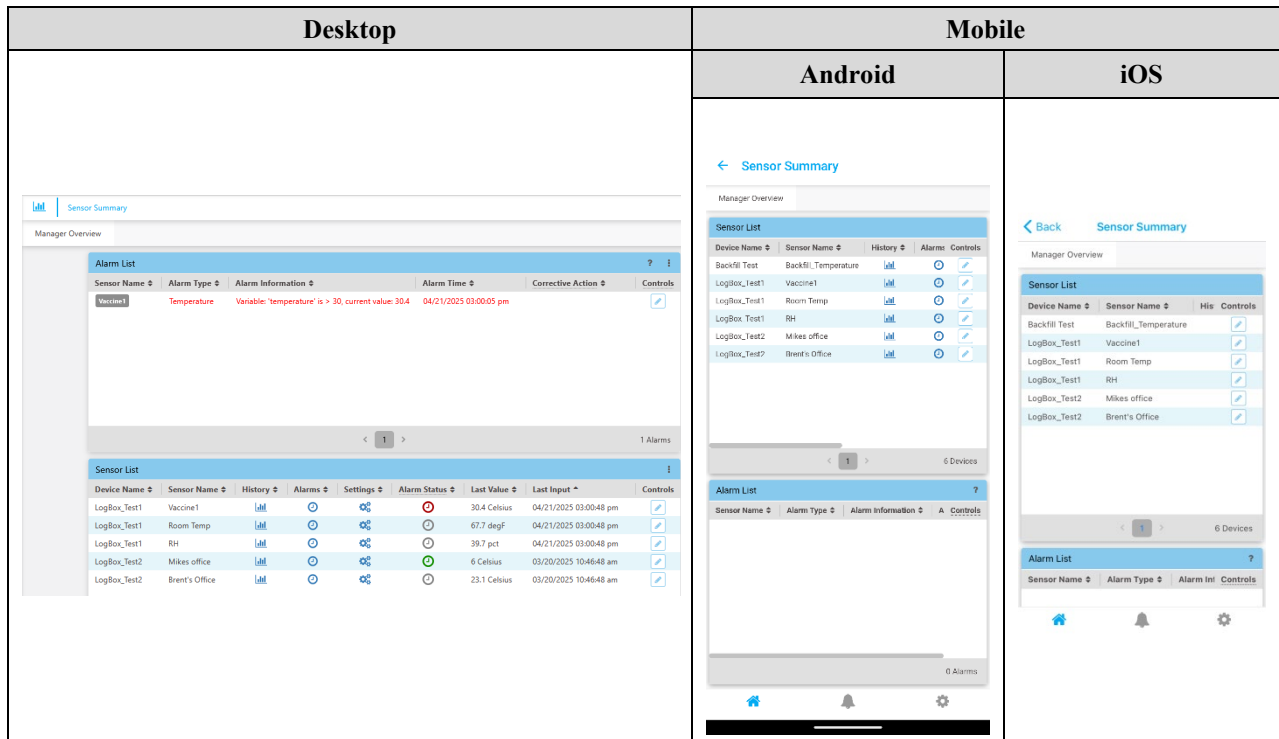

Figure 5 – Sensory Summary Window

## ALARM LIST

The alarm list window shows all of the currently active or unacknowledged sensor related alarms for your devices. Clicking the **Pencil** icon under Controls column will pop up a screen to allow you to enter the corrective action text and acknowledge the alarm which sends it to the Audit history page.

### Add Corrective Action

✕

Corrective Action

please enter the corrective action taken.

Cancel

Acknowledge

## SENSOR LIST

The sensor list window shows the sensor measurement data including the sensor name, the last received value and the date and time that the data was received. The Alarm Status column shows the current state of the sensor. A red clock indicates that the sensor is currently in an alarm state, green means the readings are within range.

The list also has 4 clickable icons to view and configure the different sensor inputs:

History Column – **Graph** icon

Clicking the graph icon under the History column will switch the view to the data for that sensor which includes the current value, the minimum and maximum within the last 24 hours, a historical trend chart and a listing of historical data values. By clicking on the 3 dots in either the graph or data list, you can export the selected data to a file.

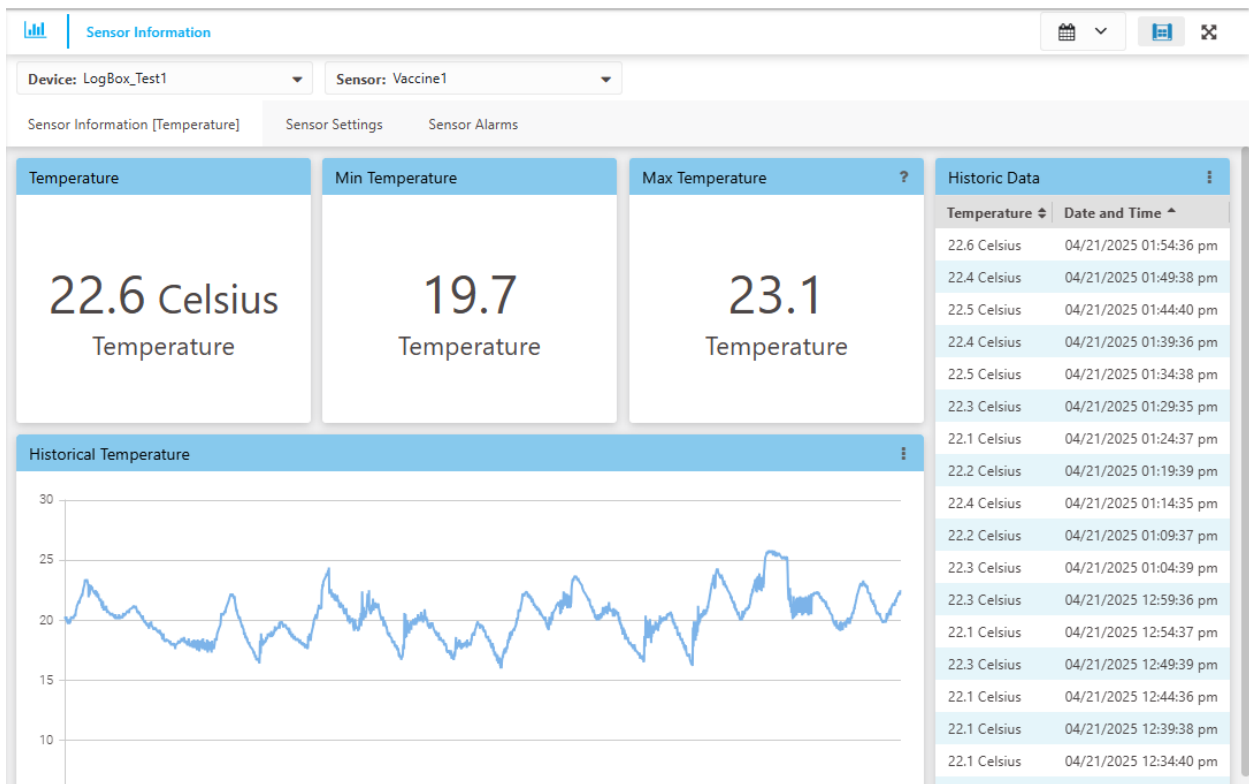

Alarms Column – **Clock** icon

Clicking the Clock Icon under the Alarms column brings up the alarm settings window.

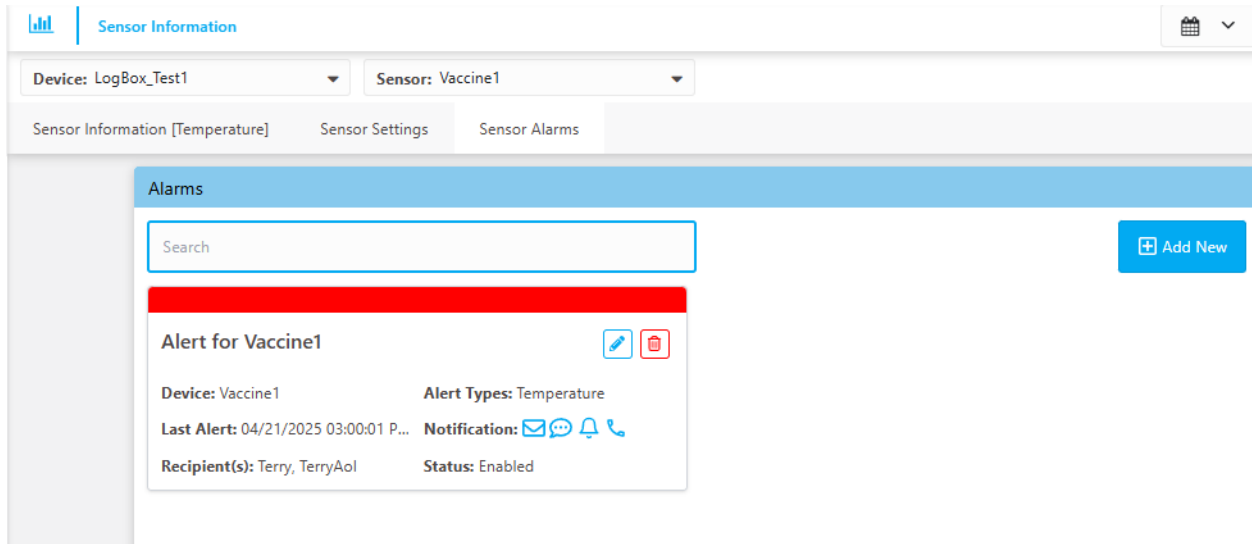

Click the **Add New** button to create a new alarm. Click the **Pencil** icon in an existing alarm to change the settings:

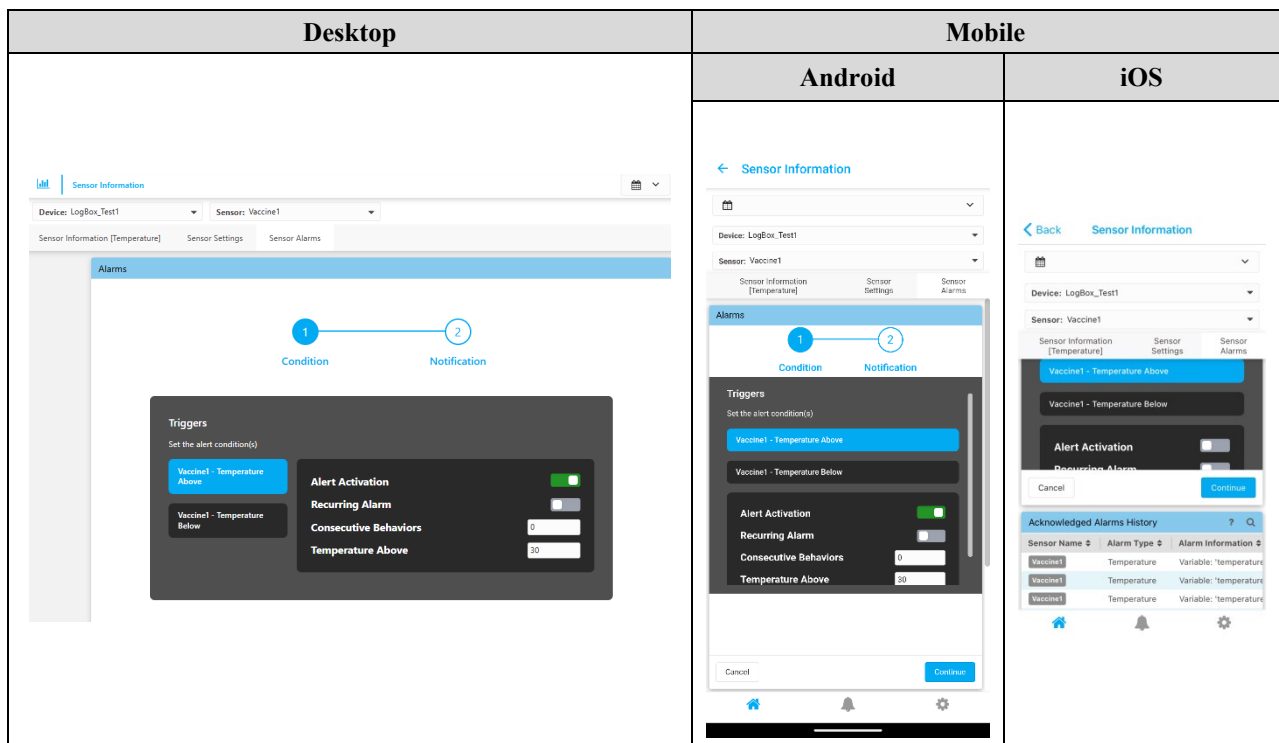

Figure 6 – Creating/Editing Alarm Conditions

On the first page of the Alarm settings window, you can change the various alarm settings

**Type of Alarm** - whether it is for above or below a particular point

**Alert Activation** - whether the alarm alert is active or not

**Recurring Alarm** - If the notification will be once or if the notification will be sent with every measurement out of range

**Consecutive Behaviors** - How many readings in a row need to be out of range before the alarm is generated

**Above/Below** - The actual alarm set point value

Once these settings are complete, click the Continue button at the bottom to go to the second page to select the type of alarm notification(s) and recipient(s):

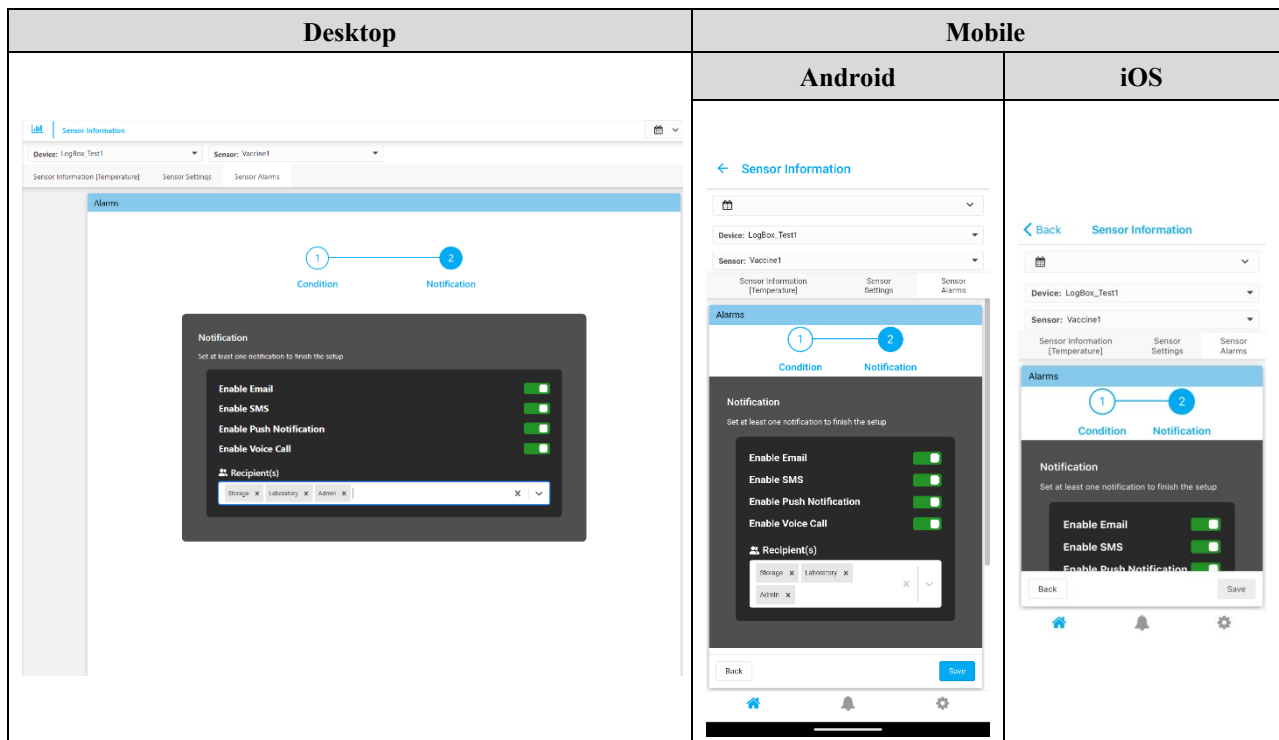
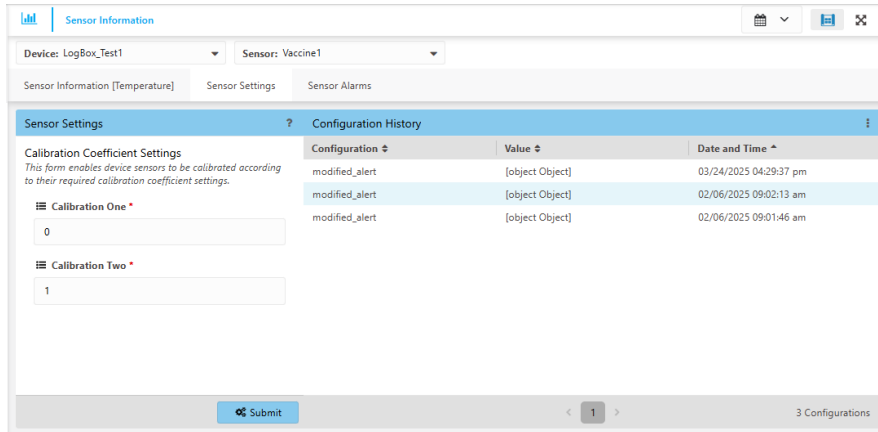

Figure 7 – Creating/Editing Alarm Notifications

The notification methods are self-explanatory. The Recipient(s) allow you to select from a list of contacts and or groups that are currently available within your account.

Settings Column – **Gear** icon

The sensor settings window allows you to configure custom calibration coefficients to apply to the raw measured data.



This window also displays any changes to the configuration of this sensor.

Controls - **Pencil** icon

Clicking the Pencil icon in the controls column allows you to change the name of the sensor that shows up on the various screens:



## DEVICES

Click on **Devices** in the left column opens the Devices Overview Page.

The **Alarm List** window shows any communications alarms for the devices in your account. If the alarm is red it indicates that the alarm is currently active. Clicking the **Pencil** icon to the right of any alarm allows you to acknowledge the alarm and enter a corrective action.

Device Name	Alarm Type	Alarm Information	Alarm Time	Corrective Action	Controls
LogBox_Test1	Communication	Communication with the device has been restored.	03/13/2025 01:52:38 pm		[Edit]
LogBox_Test1	Communication	Communication with the device has been lost.	03/13/2025 11:52:03 am		[Edit]

The **Device List** window contains a list of all of the devices associated with this account.

Status	Name	Alarm Status	MQTT Toki	Serial Num	Analog Ch	Analog Ch	Analog Ch	Digital Ch	Last Input	Controls
👍	LogBox_Test1	🕒	6e21bf...	221561...	Temper...	Temper...	Humidity	None	04/21/2025 04:45:48 pm	[Edit] [Delete] [Status]
👍	LogBox_Test2	🕒	342aef...		Temper...	None	Temper...	None	03/20/2025 10:46:48 am	[Edit] [Delete] [Status]
👍	LogboxLTE	🕒	03054a...		Temper...	None	None	None	02/04/2025 07:53:48 am	[Edit] [Delete] [Status]

The **Status** column shows if the device is currently receiving data or if it has been disabled.

The **Alarm Status** column has 3 possible states:

1. Gray the communication Alarm is disabled
2. Green the communication Alarm is enabled and the device is not in an alarm state
3. Red the communication Alarm is enabled and the device is in an alarm state

Click the **Edit Alarms** button to bring up the window to edit the communications alarms for the devices

Device List						
Name	Status	Time Interval	Recipients	Delivery Method	Controls	
LogboxLTE						
LogBox_Test2						
LogBox_Test1		15 Minutes	Terry TerryAol	Email SMS Voice Push		

Click the **Pencil** icon the **Control** column of the alarm settings window to change the communications alarm settings for any of the devices:

### Edit Device ✕

**Time Interval \***

**Recipients \***

Terry TerryAol
✕

**Delivery Method \***

Email SMS Voice Push
✕

Cancel
Confirm

On this screen you can change:

The **Time Interval** for the period of communications loss before the alarm is generated

The **Recipients** of the communications loss alarm. This can be any users or groups configured for your account.

The **Delivery Method** for alarm loss notification, email, SMS, voice and/or push notification

When these settings are complete, click the **Confirm** button at the bottom of the Alarm Settings window to save the new communication alarm settings and return to the Device List page.

There are several other settings in the **Controls** column of the Device List:

The Pencil icon allows you to change the name of the device and type of measurement for each channel of the device.

The 2 **Hand** icons are used to enable and disable receiving data from the device.

## AUDIT LOG

By clicking on the **Audit Log** button, you can open the view of all of the system log entries:

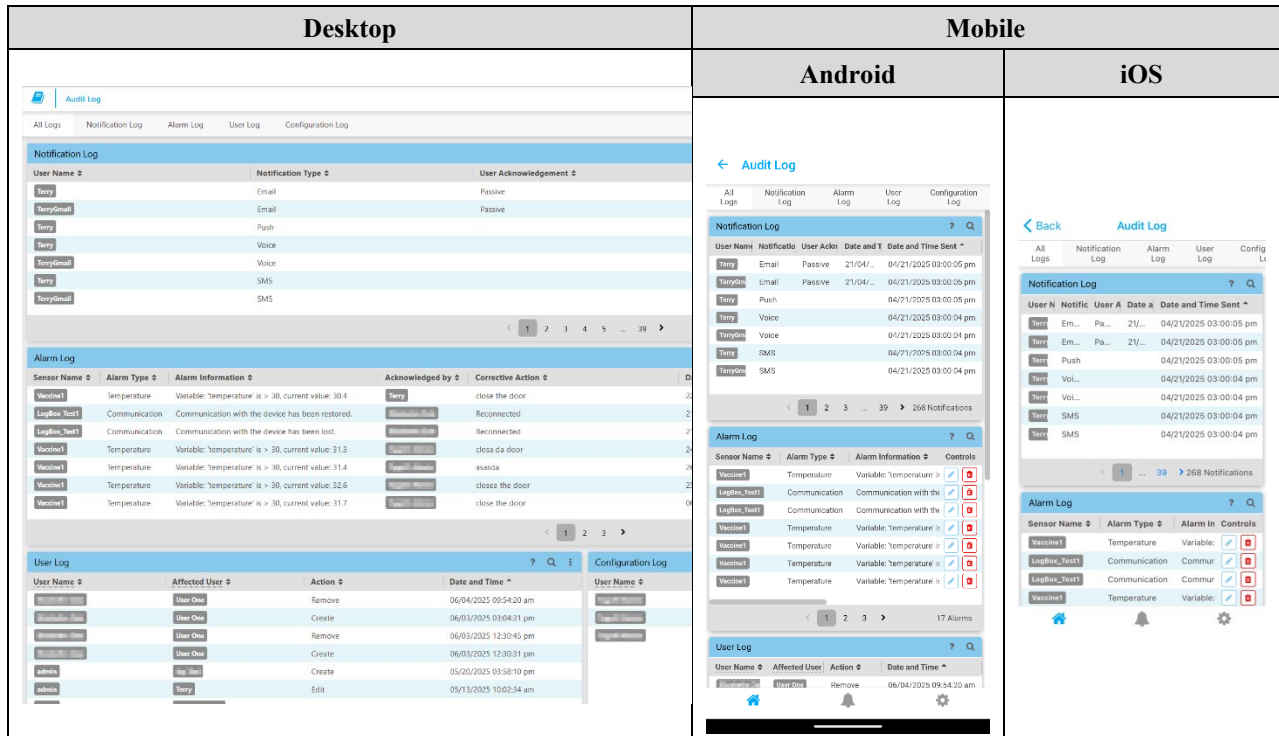

Figure 8 – Audit Log Window

By default, it opens to the **All Logs** view. There are 4 tabs at the top to open individual views of each log file.

### NOTIFICATION LOG

The notification log contains a list of the different messages (Email, SMS, Voice and/or Push) that have been sent in response to a communications loss or reconnect event along with the recipient, the date and time the message was acknowledged, and the date and time the message was sent.

User Name	Notification Type	User Acknowledgement	Date and Time Acknowledged	Date and Time Sent
Terry	Email	Passive	21/04/2025 03:00:05 PM	04/21/2025 03:00:05 pm
TerryGmail	Email	Passive	21/04/2025 03:00:05 PM	04/21/2025 03:00:05 pm
Terry	Push			04/21/2025 03:00:05 pm
Terry	Voice			04/21/2025 03:00:04 pm
TerryGmail	Voice			04/21/2025 03:00:04 pm
Terry	SMS			04/21/2025 03:00:04 pm
TerryGmail	SMS			04/21/2025 03:00:04 pm
Terry	Email	Passive	21/04/2025 02:20:16 PM	04/21/2025 02:20:16 pm
TerryGmail	Email	Passive	21/04/2025 02:20:16 PM	04/21/2025 02:20:16 pm
Terry	Push			04/21/2025 02:20:16 pm
Terry	Voice			04/21/2025 02:20:15 pm
TerryGmail	Voice			04/21/2025 02:20:15 pm
Terry	SMS			04/21/2025 02:20:15 pm
TerryGmail	SMS			04/21/2025 02:20:14 pm
Terry	Email	Passive	21/04/2025 02:09:48 PM	04/21/2025 02:09:48 pm
TerryGmail	Email	Passive	21/04/2025 02:09:48 PM	04/21/2025 02:09:48 pm

The magnifying glass will allow you to search for specific events and clicking on the 3 dots will allow you to export the data.

### ALARM LOG

The alarm log contains a list of the different messages, Email, SMS, Voice and/or Push that have been sent in response to alarm event along with the sensor name and value that generated the alarm, the date and time the message was sent, the date and time the message was acknowledged and the corrective action that was entered.

Sensor Name	Alarm Type	Alarm Information	Acknowledged by	Corrective Acti	Date and Time	Date and Time Triggered
Vaccine1	Temperature	Variable: 'temperature' is > 30, current value: 30.7	TagoIO Admin		13/01/2025 ...	01/10/2025 02:52:42 pm
Vaccine1	Temperature	Variable: 'temperature' is > 30, current value: 30.7	Terry		14/01/2025 ...	01/13/2025 12:02:32 pm
Vaccine1	Temperature	Variable: 'temperature' is > 30, current value: 30.7	TagoIO Admin		14/01/2025 ...	01/14/2025 08:37:29 am
Vaccine1	Temperature	Variable: 'temperature' is > 30, current value: 30.9	TagoIO Admin		14/01/2025 ...	01/14/2025 11:47:27 am
Vaccine1	Temperature	Variable: 'temperature' is > 30, current value: 30.3	TagoIO Admin		15/01/2025 ...	01/14/2025 04:07:29 pm
Vaccine1	Temperature	Variable: 'temperature' is > 31, current value: 31.7	TagoIO Admin		16/01/2025 ...	01/16/2025 01:32:21 pm
Mikes office	Temperature	Variable: 'temperature' is > 90, current value: 200	TagoIO Admin		17/01/2025 ...	01/17/2025 03:05:38 pm
Mikes office	Temperature	Variable: 'temperature' is > 5, current value: 200	TagoIO Admin		17/01/2025 ...	01/17/2025 03:30:54 pm
Mikes office	Temperature	Variable: 'temperature' is > 5, current value: 200	TagoIO Admin		17/01/2025 ...	01/17/2025 03:30:54 pm
Vaccine1	Temperature	Variable: 'temperature' is > 31, current value: 32	TagoIO Admin	close the do...	03/02/2025 ...	01/20/2025 08:13:19 am
Vaccine1	Temperature	Variable: 'temperature' is > 30, current value: 31.7	TagoIO Admin	close the do...	06/02/2025 ...	02/06/2025 09:09:03 am
Vaccine1	Temperature	Variable: 'temperature' is > 30, current value: 32.6	TagoIO Admin	closea the d...	25/02/2025 ...	02/25/2025 01:40:36 pm
Vaccine1	Temperature	Variable: 'temperature' is > 30, current value: 31.4	TagoIO Admin	assada	26/02/2025 ...	02/26/2025 11:25:32 am
Vaccine1	Temperature	Variable: 'temperature' is > 30, current value: 31.3	TagoIO Admin	clasa da door	24/03/2025 ...	02/26/2025 02:30:30 pm
Vaccine1	Temperature	Variable: 'temperature' is > 30, current value: 30.4	Terry	close the do...	22/04/2025 ...	04/21/2025 03:00:05 pm

The magnifying glass will allow you to search for specific events and clicking on the 3 dots will allow you to export the data.

### USER LOG

The user log contains a list of the changes to any of the user accounts within your organization .

Audit Log

All Logs Notification Log Alarm Log User Log Configuration Log

User Log

User Name	Affected User	Action	Date and Time
admin	User One	remove	06/04/2025 09:54:20 am
admin	User One	create	06/03/2025 03:04:31 pm
admin	User One	remove	06/03/2025 12:30:45 pm
admin	User One	create	06/03/2025 12:30:31 pm
admin	log	create	05/20/2025 03:58:10 pm
admin	log	edit	05/13/2025 10:02:34 am
admin	log	edit	05/13/2025 10:02:30 am
admin	John Smith	edit	05/13/2025 10:02:27 am
admin	Jane Doe	edit	05/13/2025 10:02:23 am
admin	Jane Doe	create	04/22/2025 04:17:36 pm
admin	John Smith	create	04/22/2025 04:17:05 pm
admin	log	create	04/21/2025 01:58:16 pm
admin	log	remove	03/20/2025 11:31:25 am
admin	log	create	03/20/2025 11:29:33 am
admin	log	remove	01/15/2025 10:01:16 am
admin	log	remove	01/15/2025 10:01:09 am

29 Actions

The magnifying glass will allow you to search for specific events and clicking on the 3 dots will allow you to export the data.

## CONFIGURATION LOG

The configuration log contains a list of the changes to configuration of any of the sensors and alarms for your organization .

Audit Log

All Logs Notification Log Alarm Log User Log Configuration Log

Configuration Log

User Name	Affected Sensor	Action	Date and Time
TagpIO Admin	Vaccine1	Modified Alert	03/24/2025 04:29:37 pm
TagpIO Admin	Vaccine1	Modified Alert	02/06/2025 09:02:13 am
TagpIO Admin	Vaccine1	Modified Alert	02/06/2025 09:01:46 am

The magnifying glass will allow you to search for specific events and clicking on the 3 dots will allow you to export the data.

# APPENDIX A - TROUBLESHOOTING

## START/STOP MODES

Depending on the Start/Stop rule with which the device is configured, it may lose information if it is to continue registering during a power outage.

- **Start/Stop by Keyboard:** A Modbus command or digital input may be lost during the device's power-up.
- **Immediate Start:** "Date/Time" or "Daily" parameters will return when the device is powered up again and is able to resume the clock.

## CLOCK

After a power failure, the **Accsense Wi-Fi Pro** cannot reset the clock on its own. Therefore, if the internal battery is discharged or missing and the clock information is lost, the device will not log until it is reconfigured.

After the clock is reset, data logging will automatically resume if the end mode meets the following conditions:

- **Non-Stop** or
- **Date/Time** (if it satisfies the parameters set according to the new clock setting) or
- **Daily** (according to the time configured).

In case of a power failure, the **Accsense Wi-Fi Pro** also does not retain the last value of the Accumulator Pulse Count. Therefore, when initializing the device after the clock is lost, the **Accsense Wi-Fi Pro** will assume as the value of the Accumulator Pulse Count the data present in the last register.

## ALARM INFORMATION

Alarm information, maximum and minimum values reached in each channel, as well as Date/Time of the last event are data that can be lost if the device is left out of power for more than 30 minutes. The data logged in the periodicity of logs or the digital input events, if it is configured for Event Log, are the only ones that are certainly not lost (unless a new configuration is applied, or the user chooses to clear the memory).

**NXperience** has the functionality of reporting the maximum and minimum values logged, as well as informing all logs in an alarm situation.

## ANALOG INPUTS

- When a device that is connected to the mains (a thermocouple or voltage simulator, for example) is used in the analog inputs and is not isolated, it is recommended to use a different reading interface than USB. In some cases, due to the influence of the USB cable connection (probably by ground loops), the occurrence of noise and reading Offsets have been detected.
- When operated by batteries and no acquisition is being performed, **Accsense Wi-Fi Pro** will keep the analog circuit switched off. This strategy is necessary so that it can operate for more than two years without needing to change batteries. However, some analog signal simulators (thermocouple simulator or Pt100, for example) may not be able to operate correctly with this characteristic, causing false Offsets and oscillations in the readings. If such a problem is identified, it is recommended to power the **Accsense Wi-Fi Pro** by external power supply or By USB port while using the simulator.

- Setting the local network frequency (50 Hz or 60 Hz) is important to improve the analog channels' reading performance, even if the device is running on battery power. Usually, the power grid causes interference, which can be more easily mitigated if its frequency is known on the signal read by the sensors.

## UNREGISTERED ALARMS

The alarm status information, as well as the maximum and minimum values reached in each channel, is updated by any events that trigger an acquisition, which may be a read in the log range or in the display update range. If a channel reaches a minimum or maximum value or an alarm condition during an acquisition that does not occur during the log range, it may not be logged in the memory. Thus, statuses may indicate that the channel has already reached one of these situations and the information is not available in a download.

The log range must be configured according to the maximum period allowed by the process being monitored, so that no important information is lost (and no longer being logged).

## COMMUNICATION LINK LOSS

If there is a loss of the communication link between the Broker and any of the Subscribers or the possible lack of electricity, it is possible that Subscriber will lose some of the logs subsequently published by **Accsense Wi-Fi Pro**. If this occurs, the set\_download topic allows you to request that the device resend the logs that were lost during that period, by setting a start date for it (see [Inscription Topic](#) section of the [MQTT Protocol](#) chapter).

## PROBLEMS COMMUNICATING WITH THE DEVICE VIA USB INTERFACE

If you have problems communicating the device via the USB interface, it is recommended to perform the following procedure to speed communication and minimize incompatibility issues:

- a. Open the Device Manager:

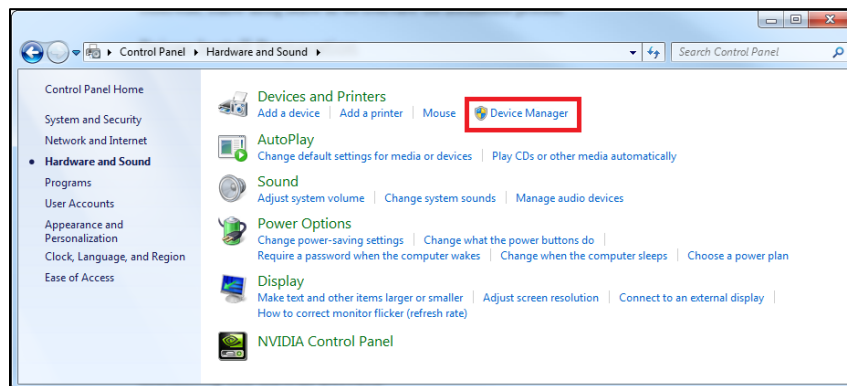

Figure 1 – Device Manager

b. Open the COM port setting of the device:

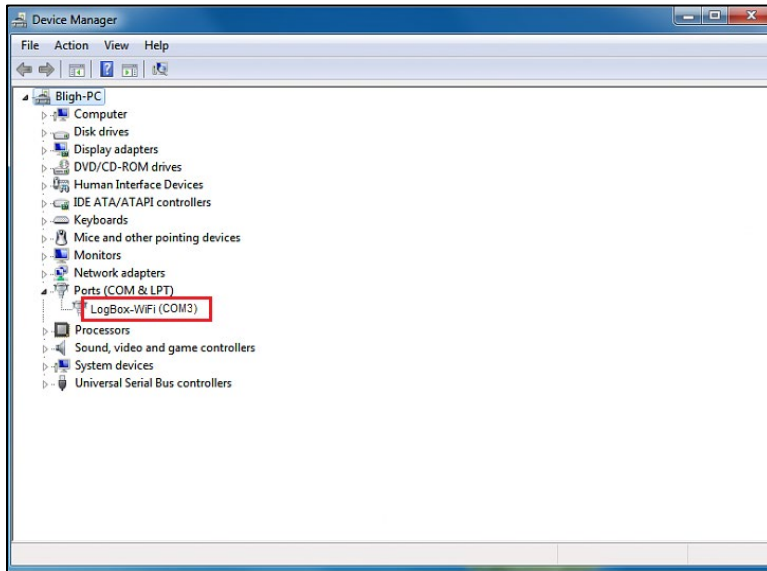

Figure 2 – Device Manager

c. Open advanced COM port configuration options:

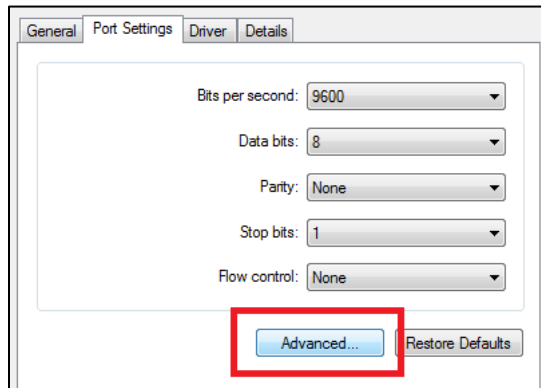

Figure 3 – Port settings configuration

d. Uncheck the Use FIFO buffers option:

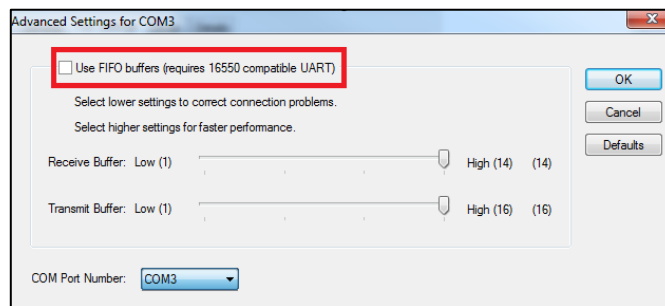

Figure 4 – Advanced settings

## PROBLEMS DURING FIRMWARE UPDATE VIA USB INTERFACE

If there are problems during the firmware update, it is recommended to perform the following procedure:

Before upgrading the firmware, verify if the latest version of **NXperience** has been installed.

If a failure occurs during firmware update, the following message will be displayed:

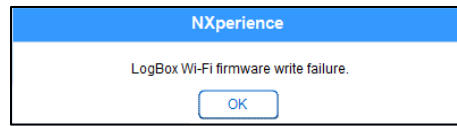

Figure 5 – Firmware failure

Click **OK** and verify if the device is still available for the update. If it is, click on **Program** again:

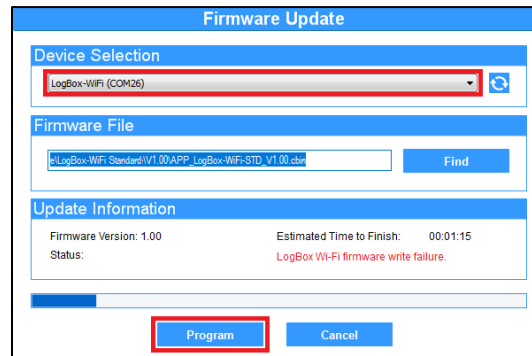

Figure 6 – Firmware update

If **NXperience** has been closed and/or it is no longer possible to find the device on the update screen, it is necessary to close the **NXperience**, turn off the **Accsense Wi-Fi Pro** and reconnect the device to the USB interface for a new attempt.

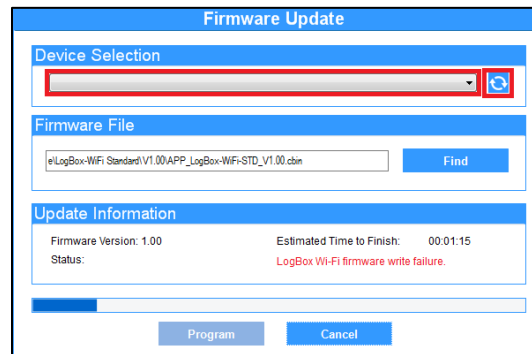

Figure 7 – Firmware failure

If the **NXperience** shows an error while reading the configuration, as shown in the figure below, and the device display is off, try the procedure described in the following step.

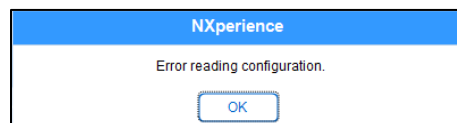

Figure 8 – Error reading configuration

On the **NXperience** startup screen, pressing the Ctrl + Shift + F12 keys simultaneously will cause the firmware update screen to reappear, as shown in **Fig. 8**.

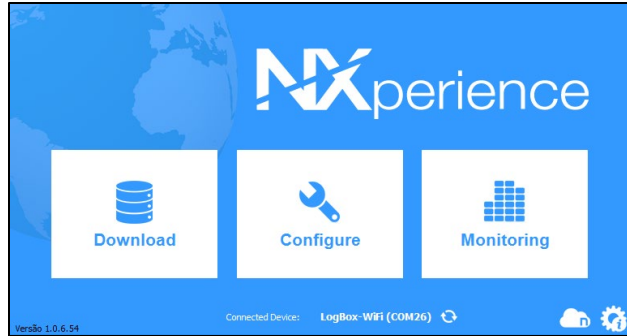

Figure 9 – NXperience home screen

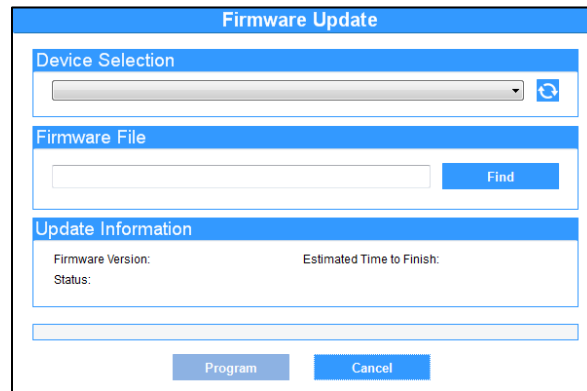

Figure 10 – Firmware update

Try to update the firmware again. If you cannot find the device, turn off the **Accsense Wi-Fi Pro** and switch it back on by holding down both keys. After that, repeat this procedure. In case of failure during previous procedures, contact **NOVUS** technical support.

## APPENDIX B – UPDATING FIRMWARE

**Accsense Wi-Fi Pro** has two firmwares: 1 located on the motherboard, which must be updated via USB, and 1 located on the Wi-Fi module, which must be updated by Over the Air technology. In a firmware update, it is important to update both. To do so, make sure you get the correct firmware versions from the **NOVUS** website and update the motherboard and the Wi-Fi module.

### FIRMWARE UPDATE VIA USB

You can update the device firmware using the **NXperience** software. On the home screen, simultaneously press the Ctrl + Shift + F12 keys. A firmware update screen will appear:

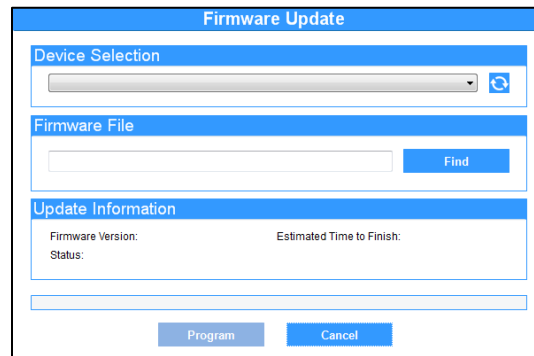

Figure 1 – Firmware update

Once this is done, select the device to be updated, add the firmware file to be used and click the **Program** button.

### OVER THE AIR (OTA) FIRMWARE UPDATE

The **Accsense Wi-Fi Pro** module can be upgraded using Over the Air (OTA) technology.

To perform this procedure, you must know the device's IP. After that, you will need to access it through a Browser. In the address bar, you must enter the device's IP address: /novus\_logbox/upgrade (192.168.88.86/novus\_logbox/upgrade (192.168.12.33, for example).

Once the Browser loads the device firmware update page, you will need to upload a .bin file, which contains the Wi-Fi module new firmware version.

The firmware update through this interface has the objective of updating network services such as MQTT, Modbus-TCP, among others. For a complete upgrade, you must use the **NXperience** software and update the rest of the device via USB.

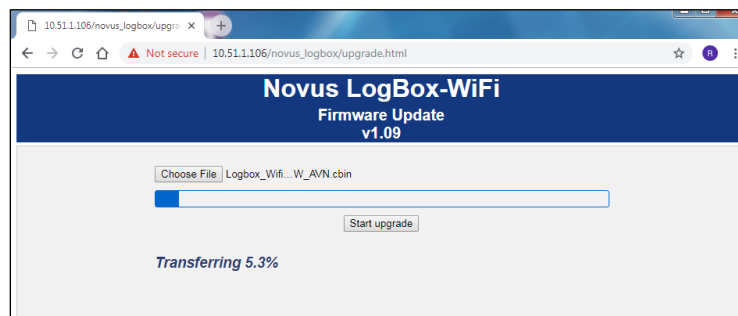

Figure 2 – Firmware update

## APPENDIX C - TECHNICAL SPECIFICATIONS

FEATURES	ACCSENSE WI-FI PRO	
<b>Input Channels</b>	3 analog inputs 1 digital input	
<b>Compatible Analog Signals</b>	Thermocouple J, K, T, N, E, R, S and B, Pt100, 0-50 mV, 0-5 V, 0-10 V, 0-20 mA, 4-20 mA	
<b>Internal Measurements</b>	Internal Temperature (NTC) Battery Voltage External Power Supply Source Voltage	
<b>Analog Channels Input Impedance</b>	Thermocouples / Pt100 / mV: > 2 MΩ mA: 15 Ω + 1.5 V V: 1 MΩ	
<b>Pt100</b>	Maximum cable offset resistance: 25 Ω Excitation Current: 166 μA Used Curve: α = 0.00385	
<b>Digital Input</b>	<b>Logical Levels</b>	Logical Level "0": from 0 to 0.5 VDC Logical Level "1": from 3 to 30 VDC
	<b>Maximum Voltage</b>	30 VDC
	<b>Input Impedance</b>	270 kΩ
	<b>Input Current @ 30 VDC (typical)</b>	150 μA
	<b>Maximum Frequency (squared wave)</b>	Dry Contact: 10 Hz PNP: 2 kHz NPN: 2 kHz
	<b>Minimum Pulse Duration</b>	Dry Contact: 50 ms PNP: 250 μs NPN: 250 μs
<b>Digital Output</b>	1 PNP-type output Maximum current that can be switched at the output: 200 mA	
<b>Display</b>	3 lines, 4½ digits	
<b>Resolution</b>	Analog Signals: 15 bits (32768 levels) Digital Signal: 16 bits (65536 levels) Digital Signal (Accumulator): 32 bits (4294967296 levels)	
<b>Memory Capacity</b>	140000 logs (total)	
<b>Log Range</b>	1 second to 18 hours	

FEATURES	ACCSENSE WI-FI PRO	
Log Type	Instant or Medium	
Log Trigger	Date/Time, Start button, digital input, software command or alarm	
Alarms	10 available alarms	
Internal Buzzer	Yes, it can be used for alarms	
Communication Interfaces	USB Interface Wi-Fi 802.11 b/g/n 2.4 GHz Interface, supporting WPA-Personal (PSK) WPA/WPA2 TKIP/AES/TKIP and AES encryption	
Software and App	<b>NXperience</b> (By USB or by TCP/IP network for desktops and notebooks) <b>NXperience Mobile</b> (By Wi-Fi for smartphones)	
Power supply	Power Supply Source	Voltage: 10 VDC to 30 VDC Maximum Consumption: 300 mA Typical Consumption: 20 mA
	Batteries	4 "AA" type alkaline batteries (included) (Wi-Fi interface disabled)
Estimated Battery Life	Maintenance of batteries is required (typically every 2 years, considering a 5-minute recording interval with Wi-Fi interface disabled)	
Operation Temperature	Using the included batteries: -10 to 50 °C Using <i>Energizer L91</i> batteries: -20 to 60 °C Using external power supply: -20 to 70 °C *	
Housing	ABS+PC	
Protection Index	IP40	
Dimensions	120 x 100 x 40 mm	
Certifications	CE, UKCA, FCC, CAN ICES-3 (A) / NMB-3 (A), ANATEL (07034-17-07089)	

Table 4 – Technical specifications

\* Be careful with the operating temperature of the batteries. Extremely high or low temperatures can cause ruptures and leaks and cause damage to the device.

### SENSORS RANGE AND ACCURACY

	Sensor	Sensor Minimum Value	Sensor Maximum Value	Sensor Resolution	Accuracy (%)
Thermocouples	J	-100.0 °C -148.0 °F	760.0 °C 1400.0 °F	0.1 °C 0.2 °F	0.15 % (F. E.) ± 0.5 °C   ± 0.9 °F
	K	-150.0 °C -238.0 °F	1370.0 °C 2498.0 °F	0.1 °C 0.2 °F	0.15 % (F. E.) ± 0.5 °C   ± 0.9 °F

	Sensor	Sensor Minimum Value	Sensor Maximum Value	Sensor Resolution	Accuracy (%)
	T	-160.0 °C -256.0 °F	400.0 °C 752.0 °F	0.1 °C 0.2 °F	0.15 % (F. E.) ± 0.5 °C   ± 0.9 °F
	N	-270.0 °C -454.0 °F	1300.0 °C 2372.0 °F	0.1 °C 0.2 °F	0.15 % (F. E.) ± 0.5 °C   ± 0.9 °F
	E	-90.0 °C -130 °F	720.0 °C 1328.0 °F	0.1 °C 0.2 °F	0.15 % (F. E.) ± 0.5 °C   ± 0.9 °F
	R	-50.0 °C -58.0 °F	1760.0 °C 3200.0 °F	0.3 °C 0.5 °F	0.15 % (F. E.) ± 0.5 °C   ± 0.9 °F
	S	-50.0 °C -58.0 °F	1760.0 °C 3200.0 °F	0.4 °C 0.7 °F	0.15 % (F. E.) ± 0.5 °C   ± 0.9 °F
	B	500.0 °C 932.0 °F	1800.0 °C 3272.0 °F	0.4 °C 0.7 °F	0.15 % (F. E.) ± 0.5 °C   ± 0.9 °F
<b>Pt100</b>	Pt100	-200.0 °C -328.0 °F	650.0 °C 1202.0 °F	0.1 °C 0.2 °F	0.15 % (F. E.)
<b>Linear</b>	0 to 50 mV	0.000	50.000	0.003 mV	0.15 % (F. E.)
	0 to 5 V	0.000	5.000	0.6 mV	0.15 % (F. E.)
	0 to 10 V	0.000	10.000	0.6 mV	0.15 % (F. E.)
	0 to 20 mA	0.000	20.000	0.001 mA	0.15 % (F. E.)
	4 to 20 mA	4.000	20.000	0.001 mA	0.15 % (F. E.)
<b>Digital Input</b>	Count Mode	0	65535		0.01 % (F. E.)
<b>Internal Sensors</b>	Temperature (NTC)	-40 °C -40 °F	125.0 °C 257.0 °F	0.1 °C 0.1 °F	0.15 % (F. E.) ± 0.5 °C   ± 0.9 °F
	Battery Voltage	3.6	6.5	0.01 V	2 % (F. E.)

	Sensor	Sensor Minimum Value	Sensor Maximum Value	Sensor Resolution	Accuracy (%)
	External Power Supply Voltage	10.00	30.00	0.01 V	2 % (F. E.)

\* F. E. = Full Scale = *Span*

Table 5 – Sensors range and accuracy

**Accuracy:** The sensor accuracy reading is measured in relation to the Full Scale and is proportional to the maximum measuring range of each sensor. For a Pt100 sensor, for example, which the **Accsense Wi-Fi Pro** can read in the range of -200 °C to 650 °C, with a precision of 0.15%, the accuracy in °C will be  $(650\text{ °C} - (-200\text{ °C})) * 0.15\% = 1.28\text{ °C}$ .

**Thermocouples:** The analog input circuit for the **Accsense Wi-Fi Pro** guarantees the accuracy specified in the Thermocouple sensors reading with a maximum cable impedance of 100 Ω. Thermocouple sensors with impedance above 100 Ω are read by **Accsense Wi-Fi Pro**. Accuracy, however, is not guaranteed. For reading the thermocouple sensors, the **Accsense Wi-Fi Pro** uses the internal temperature sensor for Cold Joint compensation (NTC). Just as with the internal temperature sensor, thermocouples may present a greater error than specified when there are sudden variations in ambient temperature. The specified accuracy is only guaranteed when the device is installed in an environment with a stable temperature for a time greater than one hour.

**Pt100:** The **Accsense Wi-Fi Pro** analog input circuit guarantees the accuracy specified in the reading of PT100 type sensors with a maximum cable resistance of up to 25 Ω. The device can read sensors with cables that have resistance above 25 Ω. In these cases, the accuracy and measurement range are not guaranteed. The **Accsense Wi-Fi Pro** performs the cable resistance compensation internally, if it is the same in the three wires that connect the device to the sensor.

**Linear 0 to 50 mV:** The analog input circuit of the **Accsense Wi-Fi Pro** guarantees the specified accuracy when reading electrical quantities of voltage type 0 to 50 mV with a maximum cable impedance of up to 100 Ω. Voltage sources with series impedance above 100 Ω can be read by **Accsense Wi-Fi Pro**. Accuracy, however, is not guaranteed.

**Linear 0 to 5 V and 0 to 10 V:** The analog input circuit of the **Accsense Wi-Fi Pro** guarantees the specified accuracy when reading electrical quantities of voltage type 0 to 5 V and 0 to 10 V with a maximum cable impedance of up to 200 Ω. Voltage sources with series impedance above 200 Ω can be read by **Accsense Wi-Fi Pro**. Accuracy, however, is not guaranteed.

**Linear 0 to 20 mA and 4 to 20 mA:** All **Accsense Wi-Fi Pro** input channels have common ground with each other as well as with the power supply source. Thus, for the **Accsense Wi-Fi Pro** to be able to correctly measure the current transmitters, it is necessary that they are fed by isolated sources or by using all current transmitters with the interconnected ground.

**Digital Input:** All **Accsense Wi-Fi Pro** input channels have common ground with each other as well as with the power supply source. For the **Accsense Wi-Fi Pro** to correctly measure the Digital Input sensor, such characteristic must be considered. For the logic levels of the sensor connected to the digital input to be correctly detected, it is recommended that the maximum series impedance with the sensor is less than 10 kΩ.

**Internal Temperature Sensor:** The **Accsense Wi-Fi Pro** has an internal temperature sensor of the NTC type that can be used for monitoring the ambient temperature. This sensor is used for the Thermocouples Cold Joint compensation. Because it is located inside the device’s casing, it may present a greater error than specified when there are abrupt variations in ambient temperature. The specified accuracy is only guaranteed when the device is installed in an environment with a stable temperature for a time greater than one hour. The sensor allows readings in a range of -40 °C to 125 °C. The temperature, however, is limited to the device’s operating range.

## WIRELESS CONNECTIVITY

**Accsense Wi-Fi Pro** has a wireless connectivity module for communicating with 2.4GHz 802.11 b/g/n Wi-Fi networks. The Wi-Fi connectivity module used is AES-BCM4343W-M1-G, from manufacturer Avnet, which provides data connectivity over Wi-Fi.

FEATURES	DESCRIPTION
WLAN Standards	IEEE 802 Part 11b/g/n (802.11b/g/n single stream n)
Antenna Port	Supports single antenna for Wi-Fi
Frequency Band	2.400 – 2.484 GHz

**Table 6 –** WLAN standards supported by **Accsense Wi-Fi Pro**

FEATURES	DESCRIPTION
Frequency band	2.400 – 2.497 GHz (2.4 GHz ISM Band)
Number of selectable sub-channels	14 Channels
Modulation	OFDM, DSSS (Direct Sequence Spread Spectrum), DBPSK, DQPSK, CCK, 16QAM, 64QAM
Supported rates	1, 2, 5.5, 11, 6, 9, 12, 24, 36, 48, 54 Mbps e HT20 MCS 0-7
Maximum receive input level	-10 dBm (with PER < 8 % @ 11 Mbps) -20 dBm (with PER < 10 % @ 54 Mbps) -20 dBm (with PER < 10 % @ MCS7)
Output power	17 dBm @ 802.11b 13 dBm @ 802.11g 12 dBm @ 802.11n
Carrier frequency accuracy	+/- 20 ppm (Crystal: 26 MHz +/- 10 ppm @ 25 °C)

**Table 7 –** WLAN Specifications of the Wi-Fi Connectivity Module

## APPENDIX D - NXPERIENCE MOBILE SPECIFIC FEATURES

### INSTALLING THE APPLICATION

To install the application, just look for **NXperience Mobile** in the Google Play Store or the App Store. After the download is finished, you should run the application.

If your smartphone has an Android version below 6.0 or an iOS version below 11, the application will not be available in the Google Play Store or the App Store.



**NXperience Mobile** uses the native iOS "Files" app to perform file management.

### OPERATION OF THE APPLICATION

The communication of the application with **Accsense Wi-Fi Pro** is done through the Wi-Fi interface of your smartphone, so it must be enabled on your device and your smartphone. The application uses the Modbus-TCP protocol to communicate with the **Accsense Wi-Fi Pro**, so this protocol must also be enabled on the device. For the communication to succeed, your device and smartphone must be connected to the same Wi-Fi network.

For information about connecting the device to the Wi-Fi network and enabling the Modbus-TCP protocol, check the [Communication Parameters](#) section of this chapter. Connecting the **Accsense Wi-Fi Pro** to the Wi-Fi network must be done through the **NXperience** software before any pairing attempt occurs between your smartphone and the device.

The initial screen of the Android application has four icons: **Configuration**, **Monitoring**, **Download** and **File Manager**. The iOS app home screen, on the other hand, has five icons: **Configuration**, **Monitoring**, **Downloading** and **File Manager**, which bring the main features of the application, and **Preferences**, whose icon is on the upper right side of the screen.

For the Android application to be used to configure and download the **Accsense Wi-Fi Pro** device, you must click the Wi-Fi button . To use the iOS application, you must click on the button at the top of the screen .

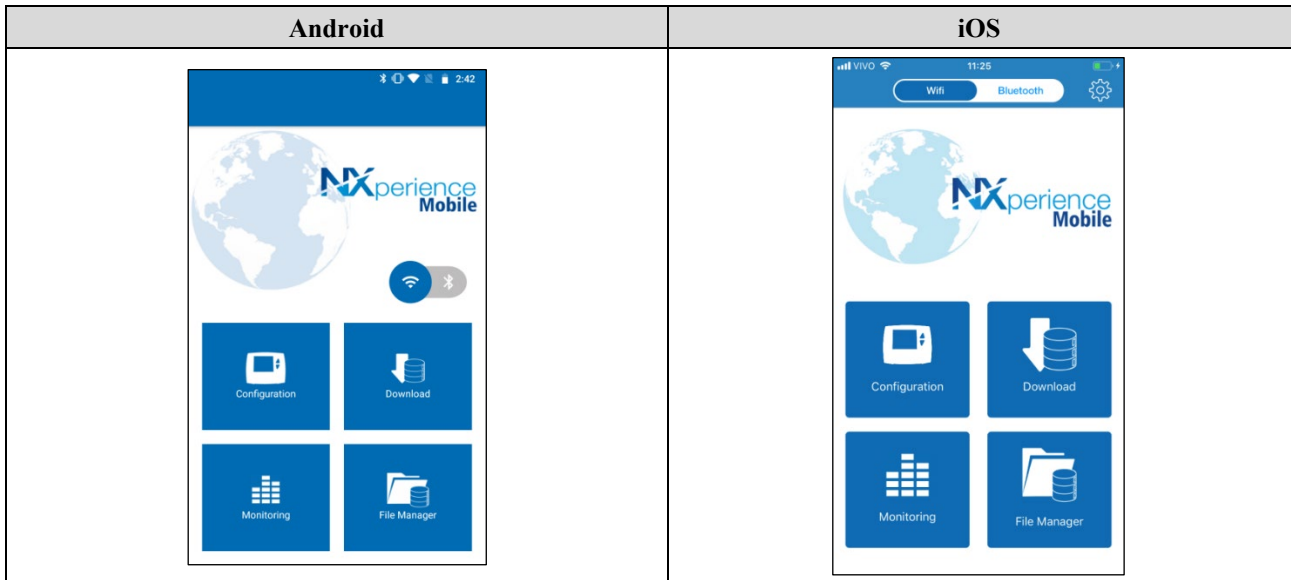

Figure 3 – Application home screen

## DOWNLOAD LOGS

You can access this feature by selecting the **Download** option from the application's home menu.

Your device and smartphone must be pre-connected to the same Wi-Fi network to pair your smartphone with the **Accsense Wi-Fi Pro**. After that, you must complete the connection data, as shown below:

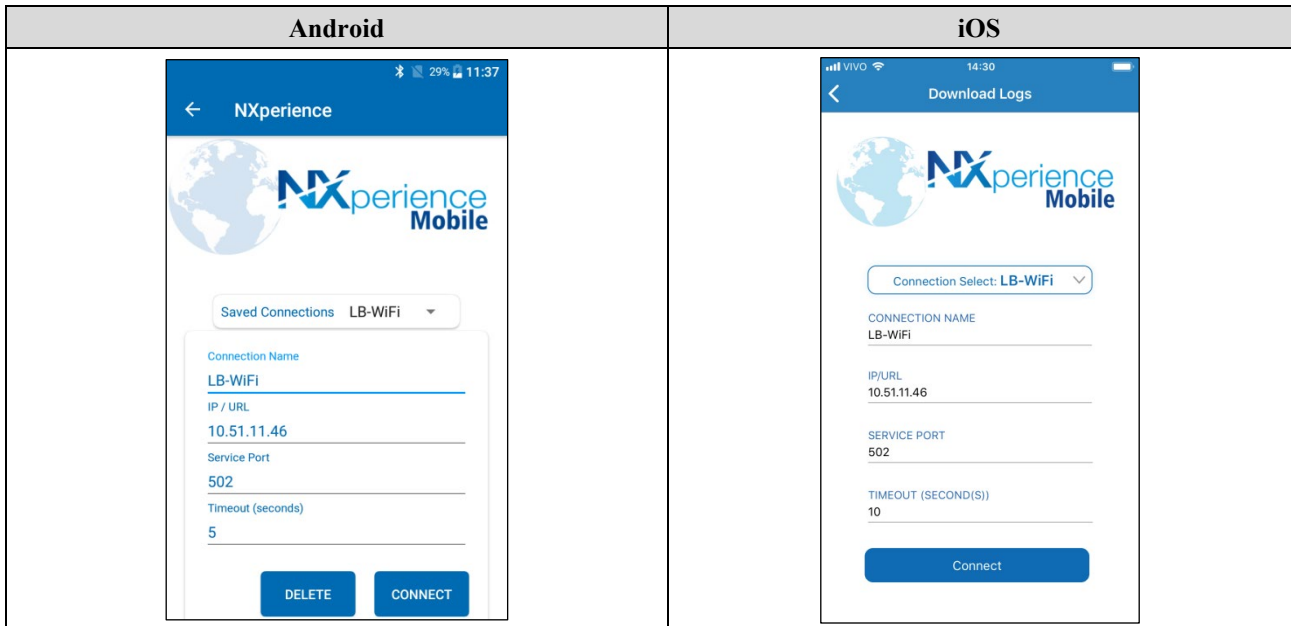



Figure 4 – Wi-Fi Connection

You can determine a specific name for each connection, which will be automatically saved and appear as an option in **Saved Connections**, by naming it in the **Connection Name** field.

To connect the application to the **Accsense Wi-Fi Pro**, you must enter the IP address of the device and the service port number used (see [Navigation Screens](#) for information about the IP address of the device).

To delete a saved connection, simply select it in the **Saved Connections** field and click the  button.

Once the connection to the device is complete, a selection screen for the download period will be available.

The **Download from Date** parameter will be automatically filled by the application with the date/time of the first log. The **Download to Date** parameter will be filled with the most recent log date/time.

If there are logs in the chosen period, you can freely change the dates.

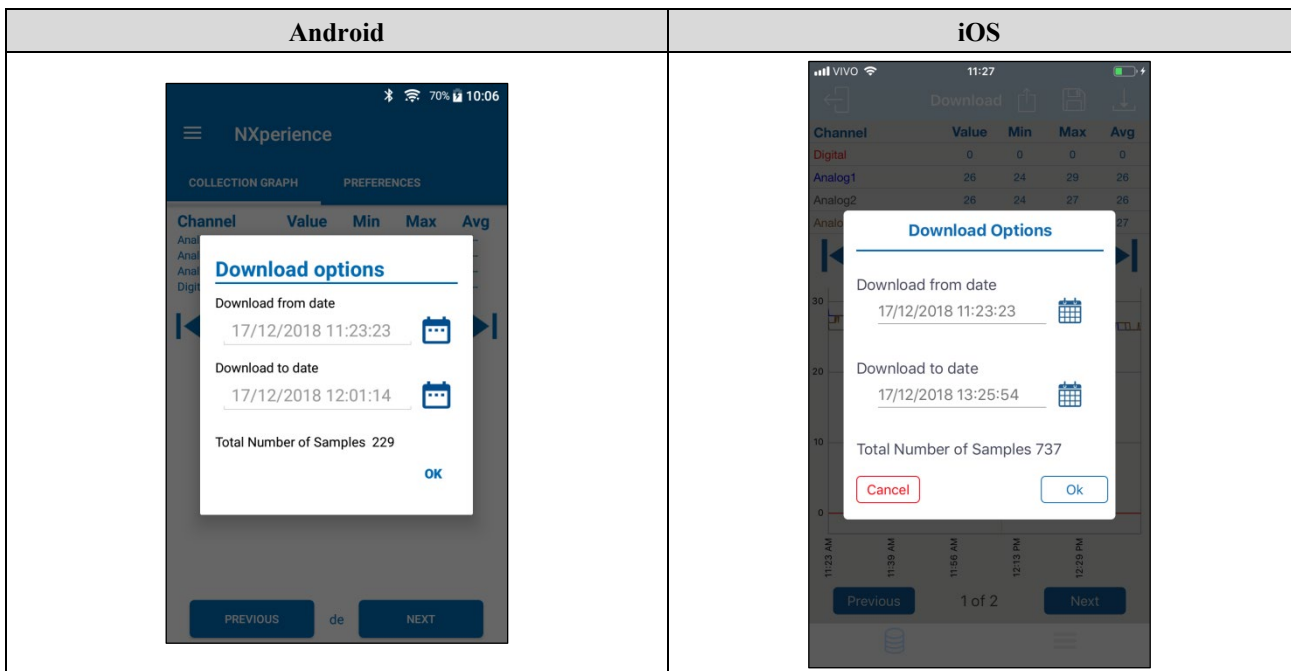

Figure 5 – Download options

The more logs downloaded, the longer the data download process takes and the greater the consumption of the device during download. This time depends on the quality of the Bluetooth connection between smartphone and **Accsense Wi-Fi Pro**. For a satisfactory experience, it is suggested to divide a very large data download into two or more steps.

A typical download, smaller than 3000 logs, lasts around 60 seconds. A full memory download, however, can take more than 20 minutes to be completed. Both times of download duration depending on the Wi-Fi signal quality.

If the download is slow, it is recommended to bring the smartphone closer to the **Accsense Wi-Fi Pro** that is being downloaded.

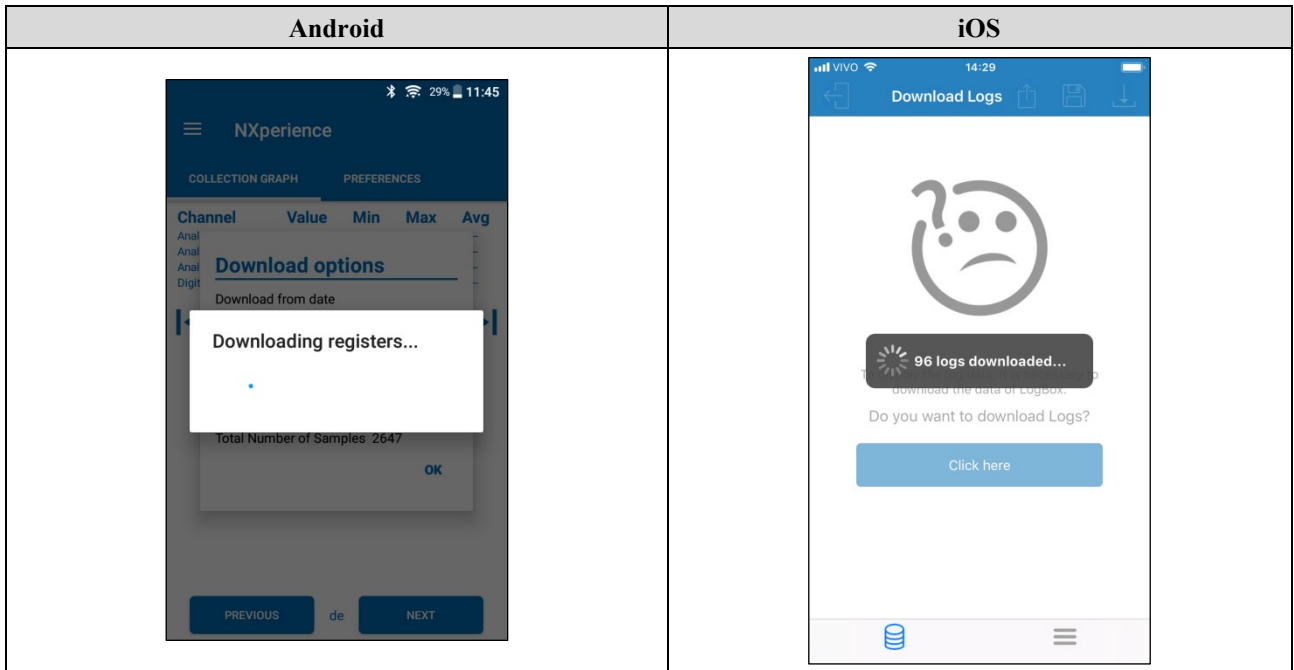

Figure 6 – Downloading logs

If **Accsense Wi-Fi Pro** does not have logs, the application displays the message shown below:

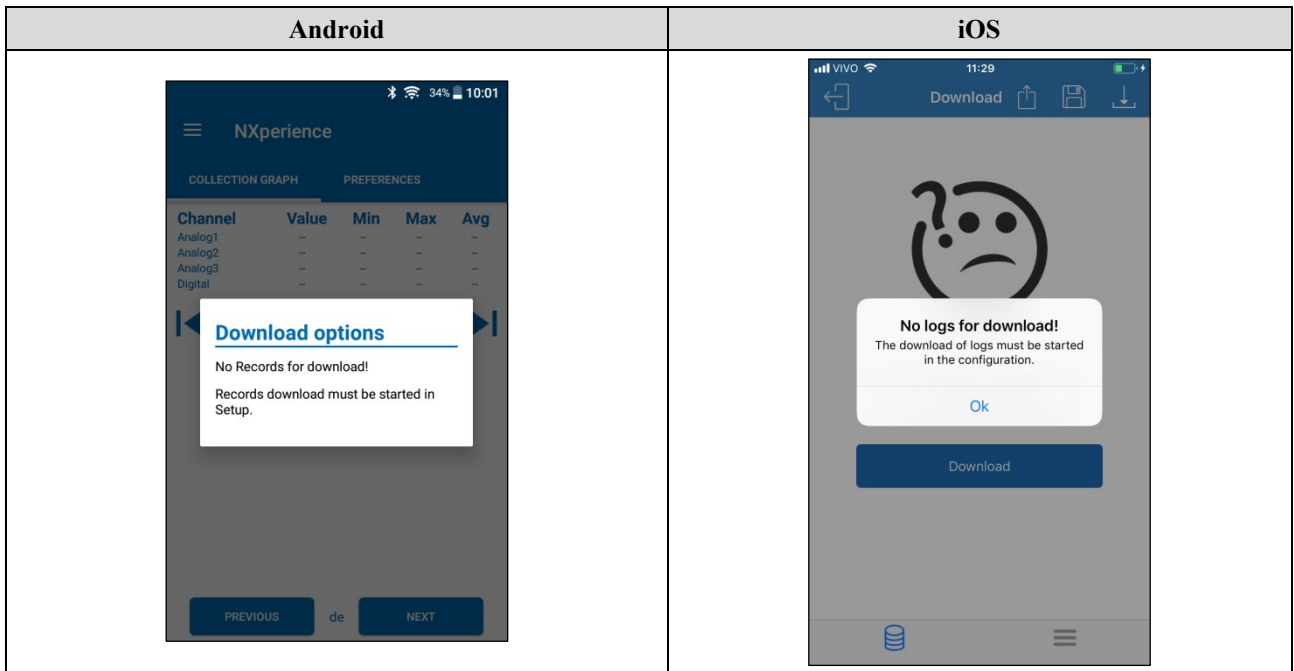

Figure 7 – Accsense Wi-Fi Pro without logs

## CHART

This screen allows you to view the data history at different time ranges and in a graphically way. It also shows the maximum value, the minimum value, and the average recorded value of each channel during the download period.

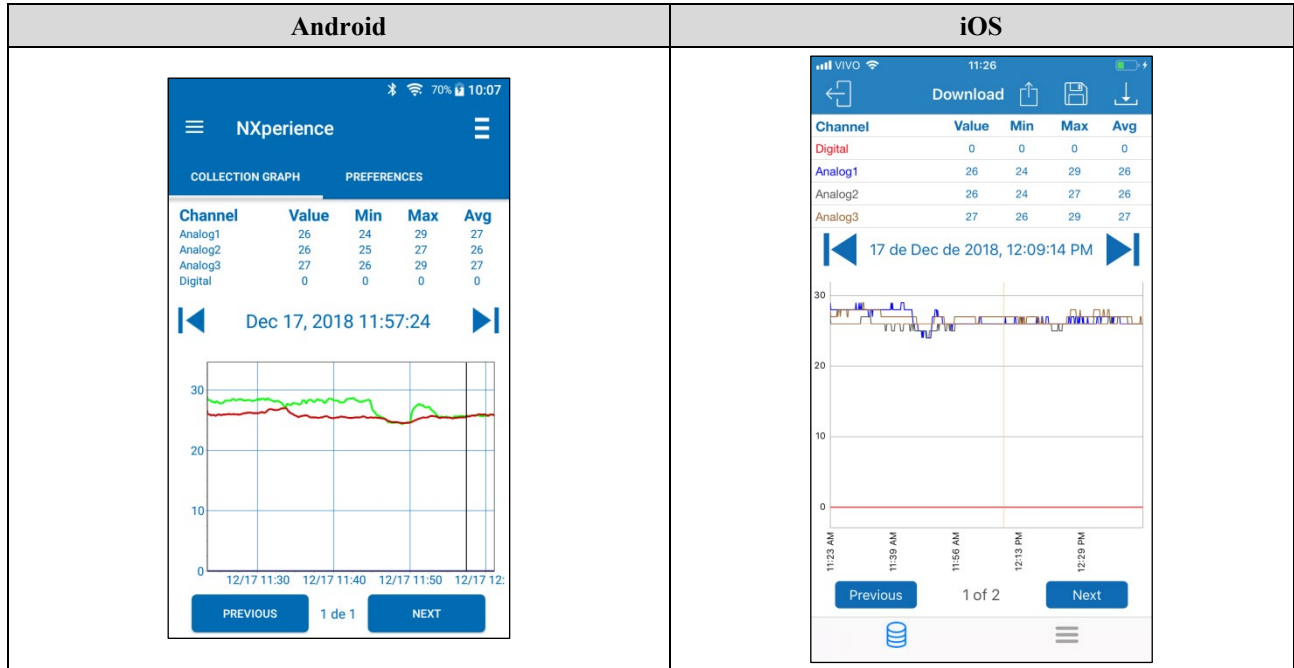





Figure 8 – Chart screen

Tapping on a point in the graph lets you see the value and time displayed at that point.

The number of logs displayed in the chart is limited to allow better viewing on your smartphone. Each screen displays 500 acquisitions. To navigate the chart and view the other logs, you must use the  and  arrows. They will allow you to roll back or advance through 500 acquisitions.

## LOG SCREEN OPTION MENU

For the Android application, pressing the icon  in the upper right corner of the screen will show the options shown and described in figure below. For the iOS application, as you can see, the icons for **Download**, **Save Files** and **Share** will automatically appear.

Android	iOS
---------	-----

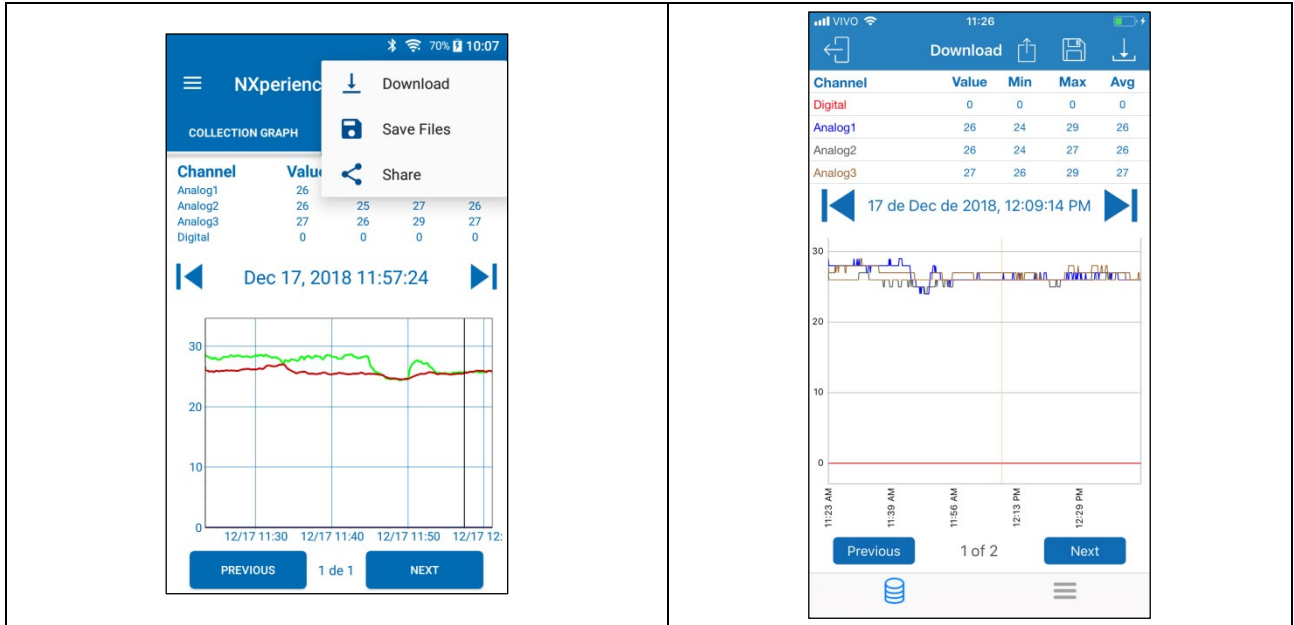



Figure 9 – Log screen option

**Download:** By pressing the  icon, the user can perform a new data download. Thus, the previously performed download will be discarded, updating the event and graphic screens, which will always display information from the last download made.

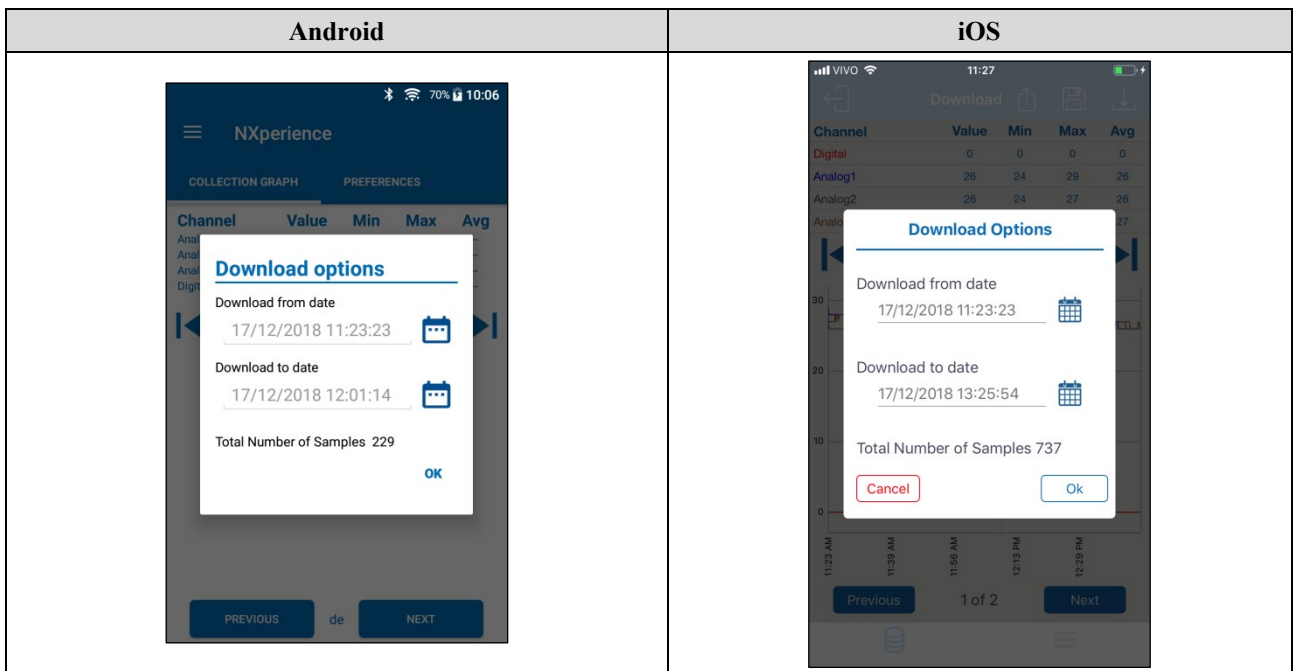



Figure 10 – Download logs

**Save Files:** By pressing the  icon, the user can save the downloaded files in the smartphone memory. The application will send a message informing that the files have been saved.

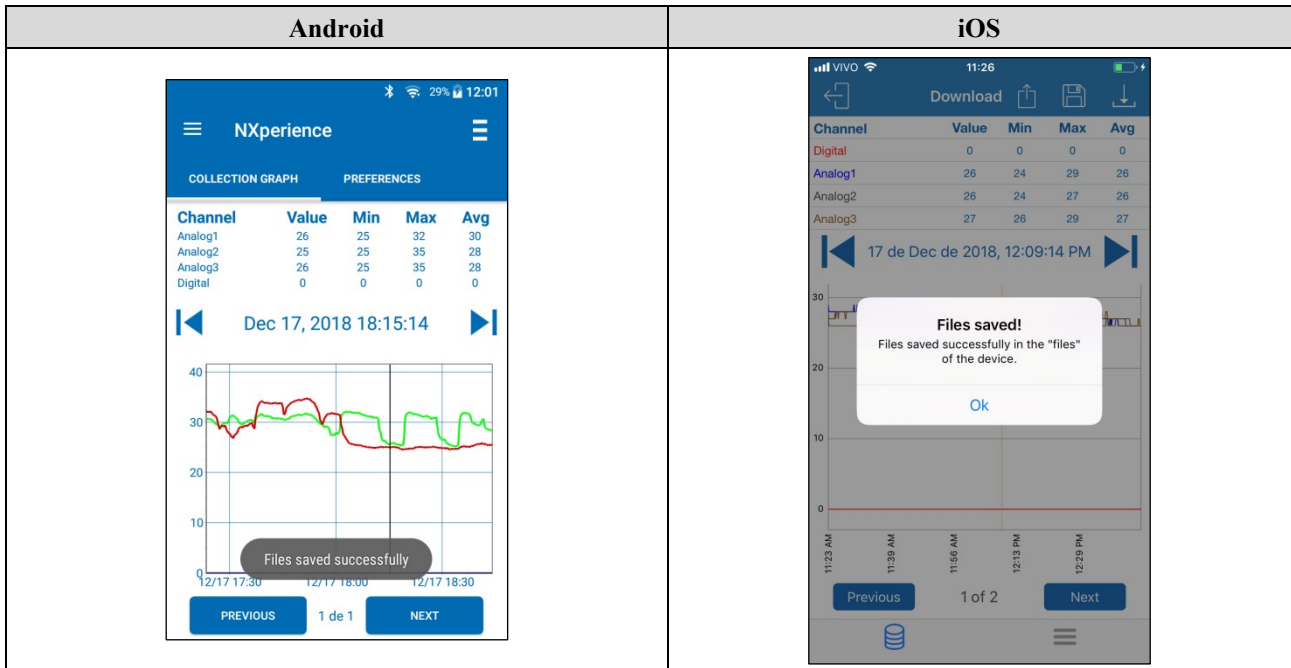



Figure 11 – Files saved successfully

**Share:** By pressing the  icon, the user can share the downloaded data using sharing applications already installed on the smartphone.

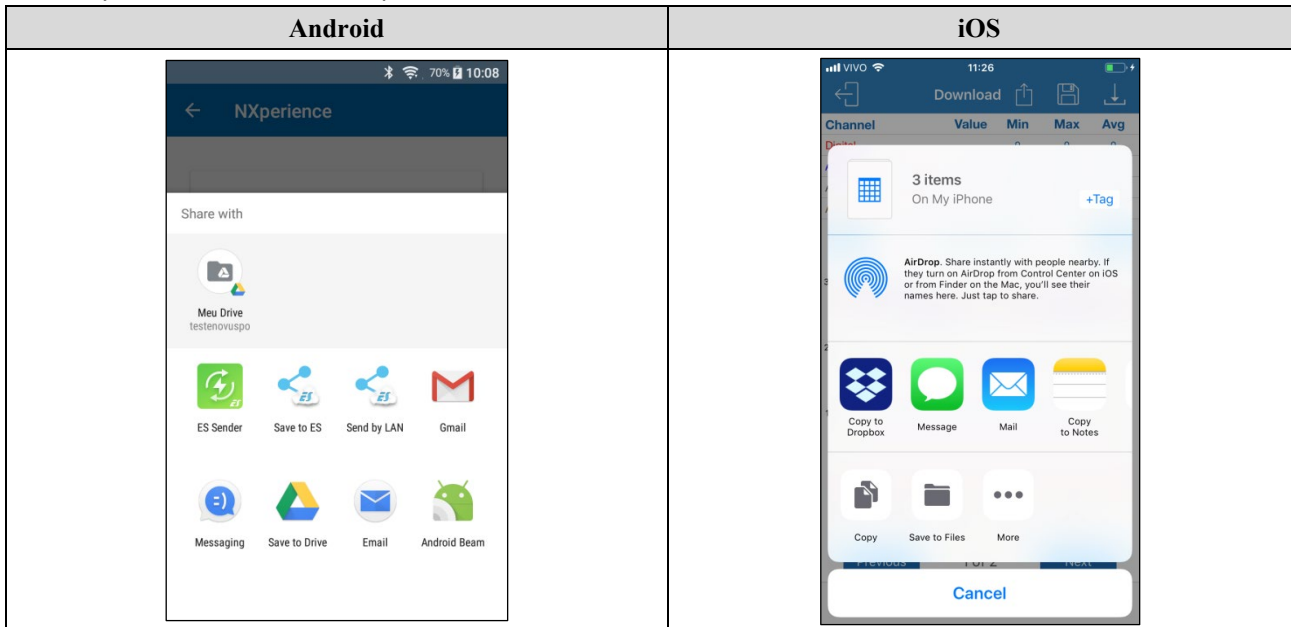



Figure 12 – Data sharing screen

The files that will be downloaded, saved, and shared will obey the **Default Sharing Options** on **Preferences** screen (see [Preferences](#) topic).

### SHORTCUTS MENU

Clicking the  icon on the Android application, positioned on the upper left side of the application, opens a shortcut tab, which can redirect the application to the file manager or to the home screen and allow you to show the application version.

Clicking the  icon on the iOS application, positioned at the bottom of the application, opens a shortcut tab, which can redirect the application to the file manager, the preferences menu, the password configurations, and other options.

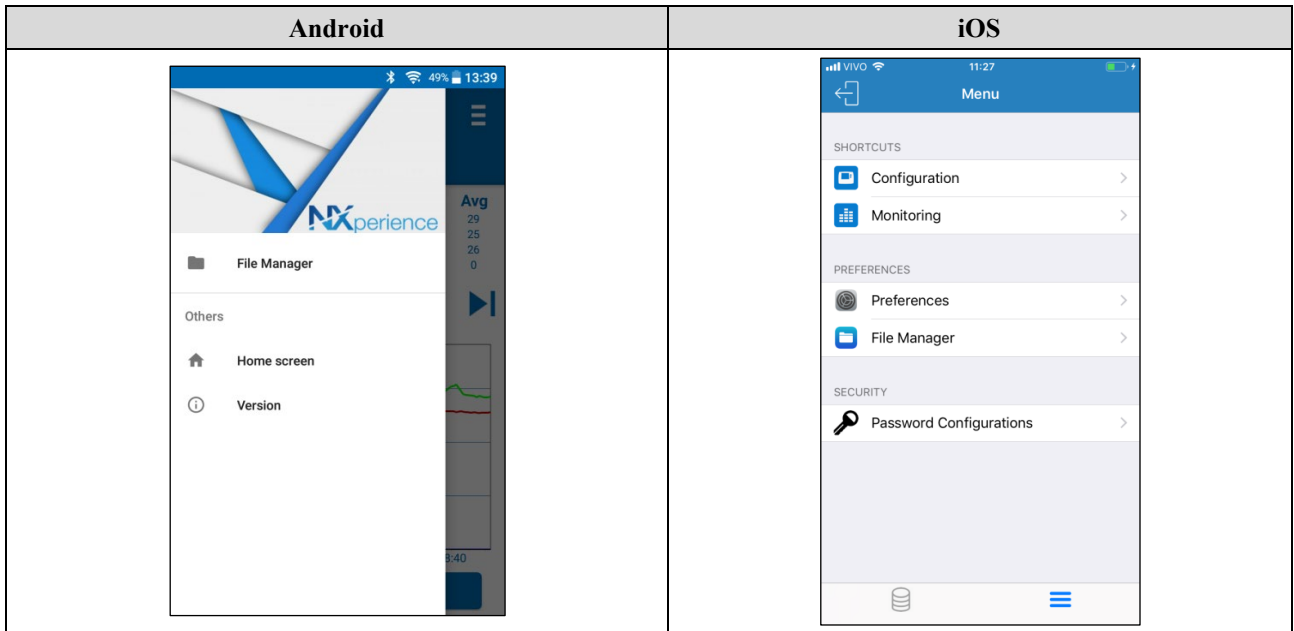

Figure 13 – Shortcuts menu

## PREFERENCES

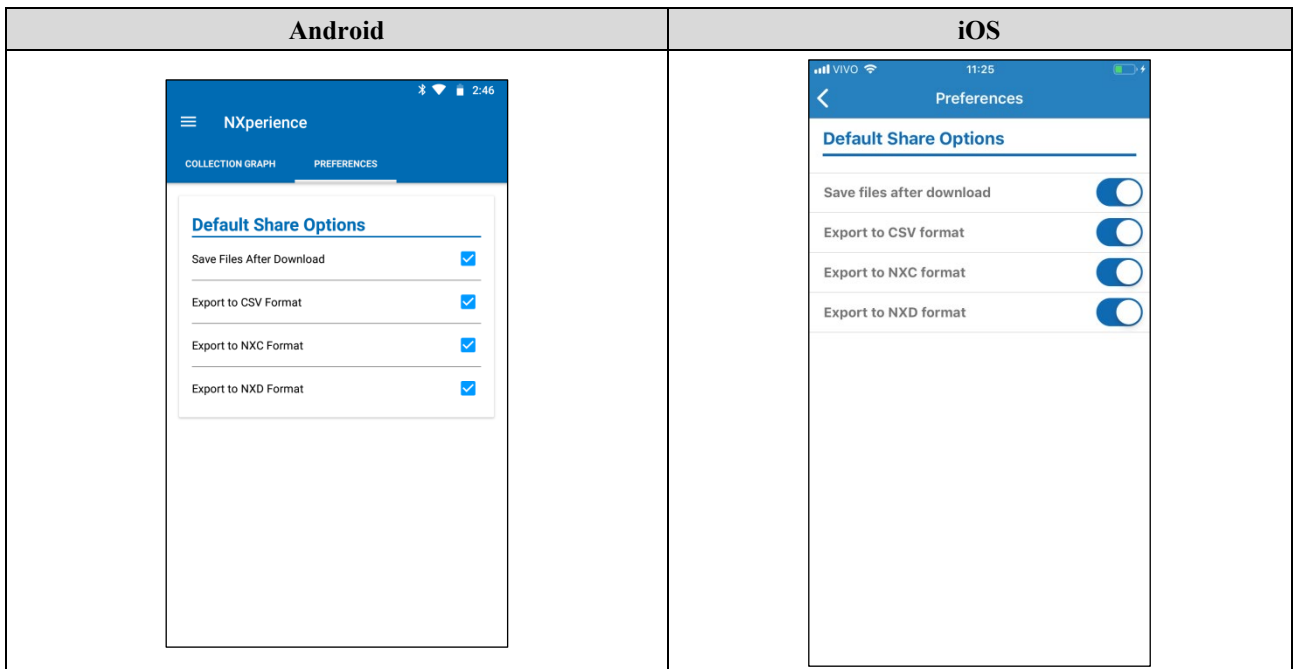

Figure 14 – Preferences

- **Default Share Options:** The user can configure how they want to share the data downloaded from **Accsense Wi-Fi Pro** and managed by **NXperience Mobile**.
  - **Save Files after Download:** Configures the application to save the downloaded files in the smartphone internal memory.
  - **Export to CSV format:** Configures the application to share a .csv extension file with all the logs from last download. This file can be opened by using *Microsoft Office Excel*.
  - **Export to NXC format:** Configures the application to share a file with **Accsense Wi-Fi Pro** configuration in a format compatible with **NXperience** (.nxc).
  - **Export to NXD format:** Configures the application to share a file with the downloaded data in a format compatible with **NXperience** (.nxd).

## MONITORING

The **Monitoring** section provides information about the values downloaded by the device.

### MONITORING

This screen provides information about the active channels, informing the current value and the maximum and minimum values downloaded by each channel.

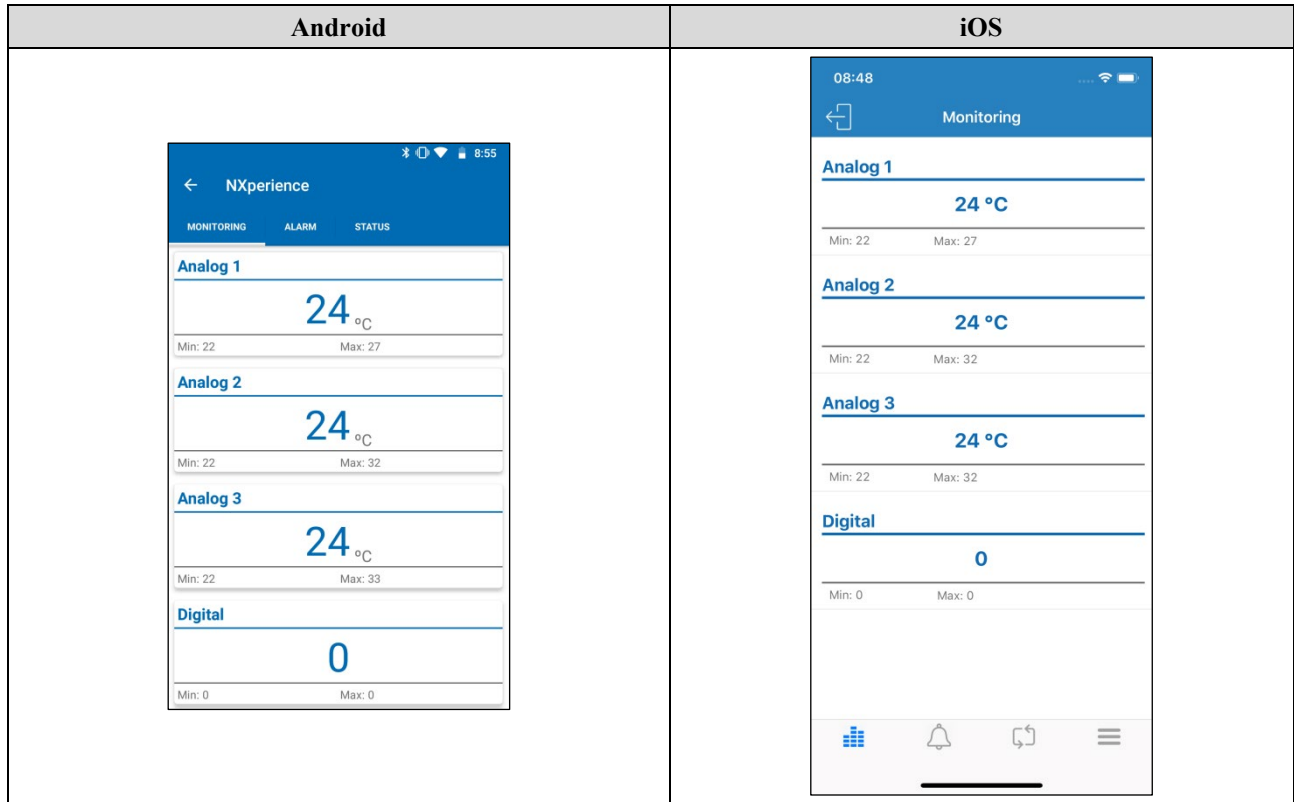

Figure 15 – Monitoring

### ANDROID NOTIFICATIONS

Functionality available only for the Android application, the device will display notifications to report alarms that are in an alarm situation and about the time and conditions in which they occurred when the application is in the background.

Alarm Notifications	End of Alarm Notifications
<p>now ▾ alarm_02 Analog1 &gt; Analog2 At 14:12:13</p>	<p>now ▾ alarm_02 End of alarm Analog1 &gt; Analog2 At 11:23:13</p>

Table 8 – Alarm Notifications

## ALARMS

This screen provides information about alarms (configured in the **NXperience Alarms Configuration** section) that are in an alarm situation. Each alarm on this screen displays the channels to be compared, the previously selected operation, and the Offset, Range or Hysteresis values set for each one.

For more information on the function of each operation and the specific parameters of each channel, just check the [Alarms](#) chapter of this manual.

If there is no alarm situation, the message "No alarms" will be displayed.

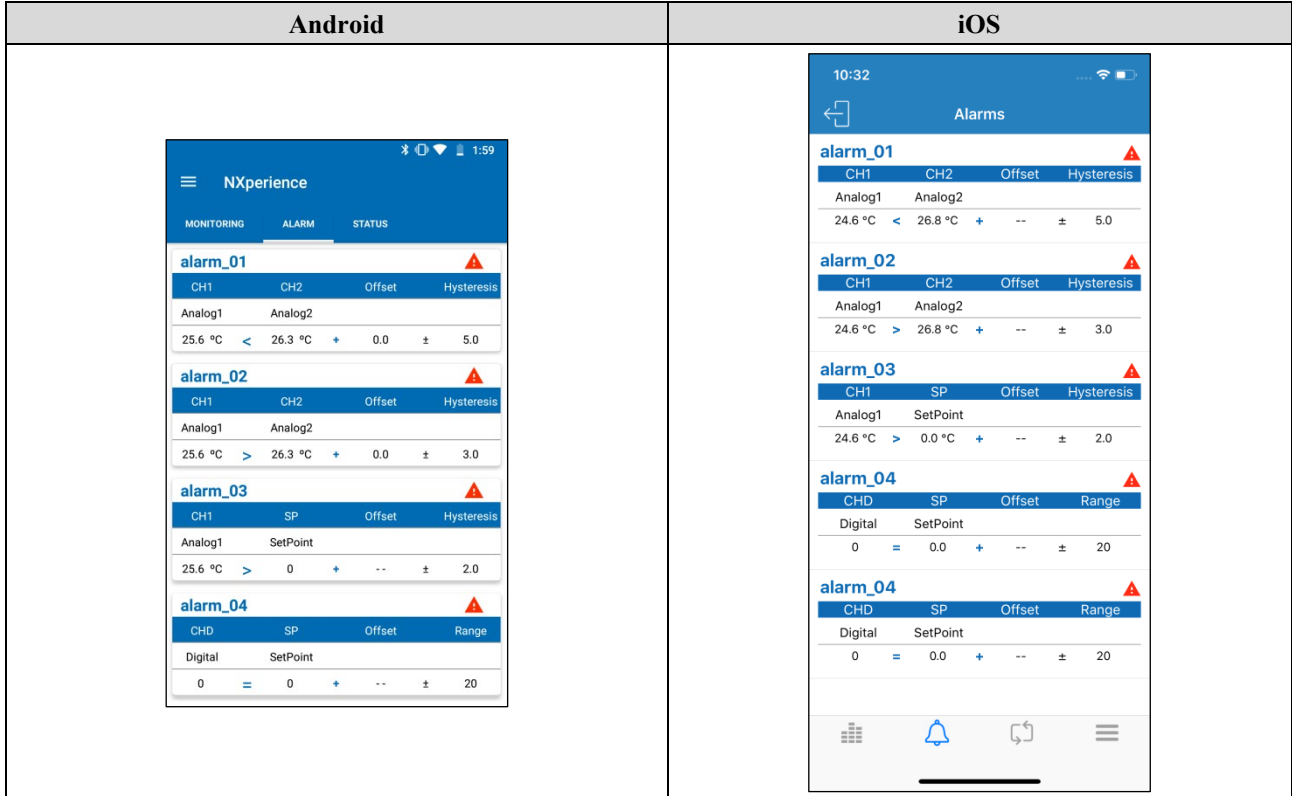

Figure 16 – Alarm monitoring

## STATUS

This screen displays the same information about the device, such as the status of the logs, the number of logs available, the serial number of the device, the firmware version of the device, etc.

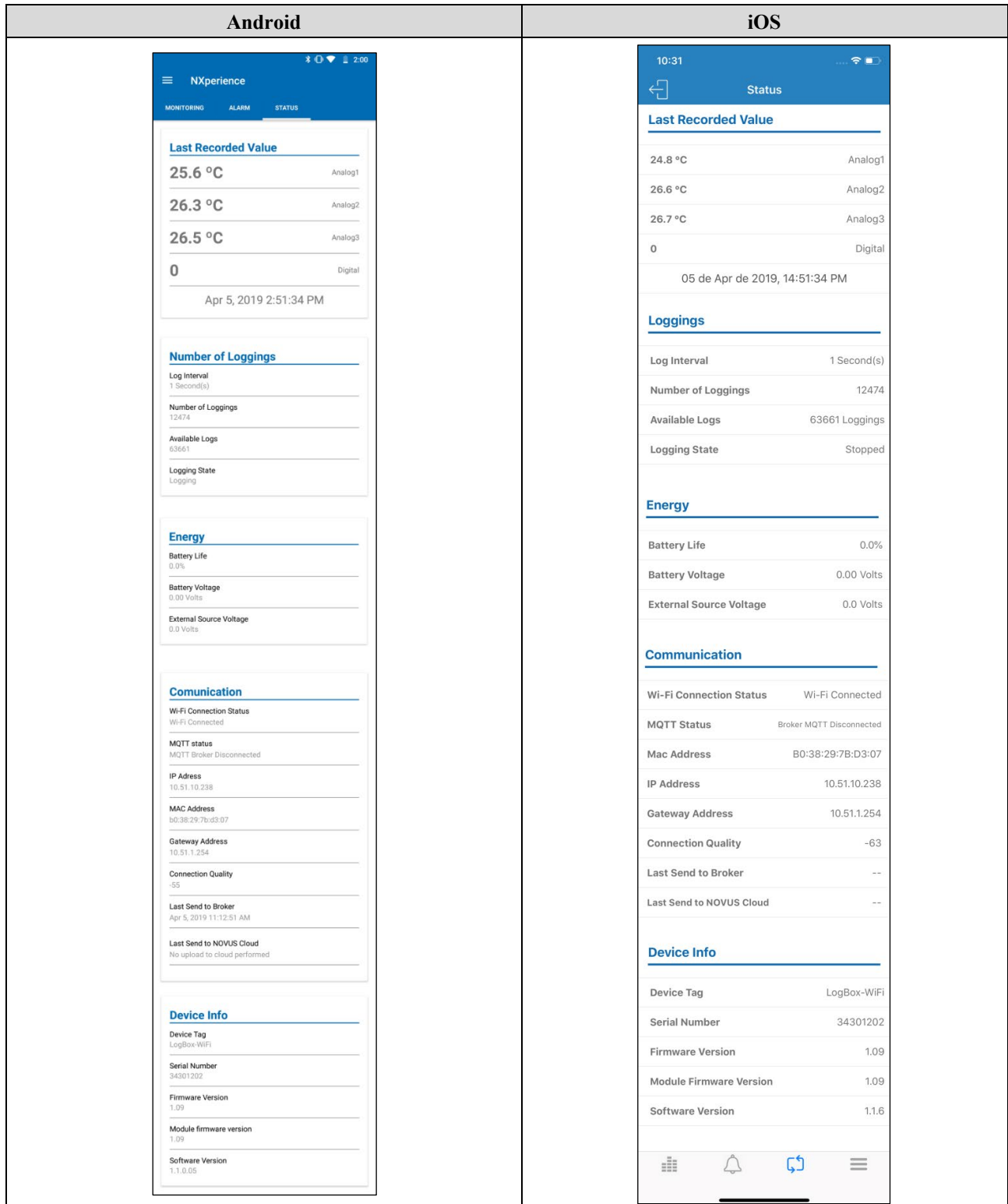

Figure 17 – Status

- **Last Recorded Value:** Displays the value of the last acquisition made by the **Accsense Wi-Fi Pro** for each channel. The last acquisition may not have been recorded in memory.
- **Number of Loggings:** Displays basic information about **Accsense Wi-Fi Pro** logs.
  - **Log interval:** Displays the value of the configured range of logs.
  - **Number of Loggings:** Displays the number of logs made by the Accsense Wi-Fi Pro.
  - **Available Logs:** Displays the available number of logs.
  - **Logging State:** Reports whether the device is registering or is stopped.
- **Energy:** Displays information about the possible power supplies of the **Accsense Wi-Fi Pro**.
  - **Battery Life:** Displays the remaining percentage of the battery.
  - **Battery Voltage:** Displays the battery voltage in Volts.
  - **External Source Voltage:** Displays external power supply voltage in Volts.
- **Communication:** Displays the settings about the device's Wi-Fi communication.
  - **Wi-Fi Connection Status:** Displays the status of the Wi-Fi communication. Because Wi-Fi needs to be enabled, the status will always be enabled to be able to read information through the application.
  - **MQTT Status:** Displays the status of the MQTT.
  - **IP Address:** Displays the IP address of the device.
  - **MAC Address:** Displays the MAC address of the device.
  - **Gateway Address:** Displays the Gateway address of the device.
  - **Connection Quality:** Displays, in dBm, the signal strength of the connected device (this value is obtained on the initial screen at the time of the search, i.e., this value is not updated periodically).
  - **Last Send to Broker:** Displays information about the last shipment made to the Broker.
  - **Last Send to NOVUS Cloud:** Displays information about the last shipment made to the NOVUS Cloud.
- **Device Information:** Displays specific **Wi-Fi LogBox** information.
  - **Device Tag:** Displays the name configured by the user.
  - **Serial Number:** Displays the factory-preset serial number.
  - **Firmware Version:** Displays the firmware version of the device.
  - **Module Firmware Version:** Displays the firmware version of the Wi-Fi module.
  - **Software Version:** Displays the version of the application.

## FILE MANAGER

This screen allows you to erase and share data from previously performed downloads. It displays a list containing all downloads performed and saved by the user, separated by the downloaded **Accsense Wi-Fi Pro** serial numbers. In this list you can select the desired files and share or delete them.

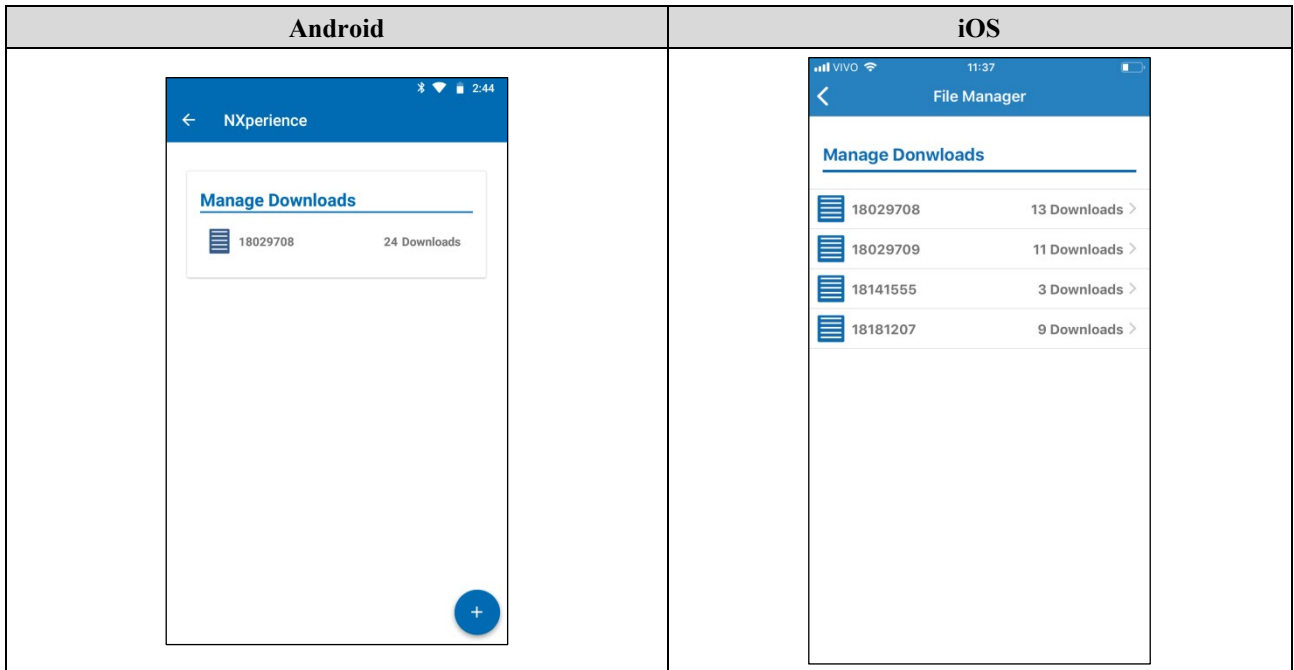

Figure 18 – File Manager screen

By clicking on the desired **Accsense Wi-Fi Pro**, identified by the serial number, **NXperience Mobile** will expand a list containing all saved downloads from that device.

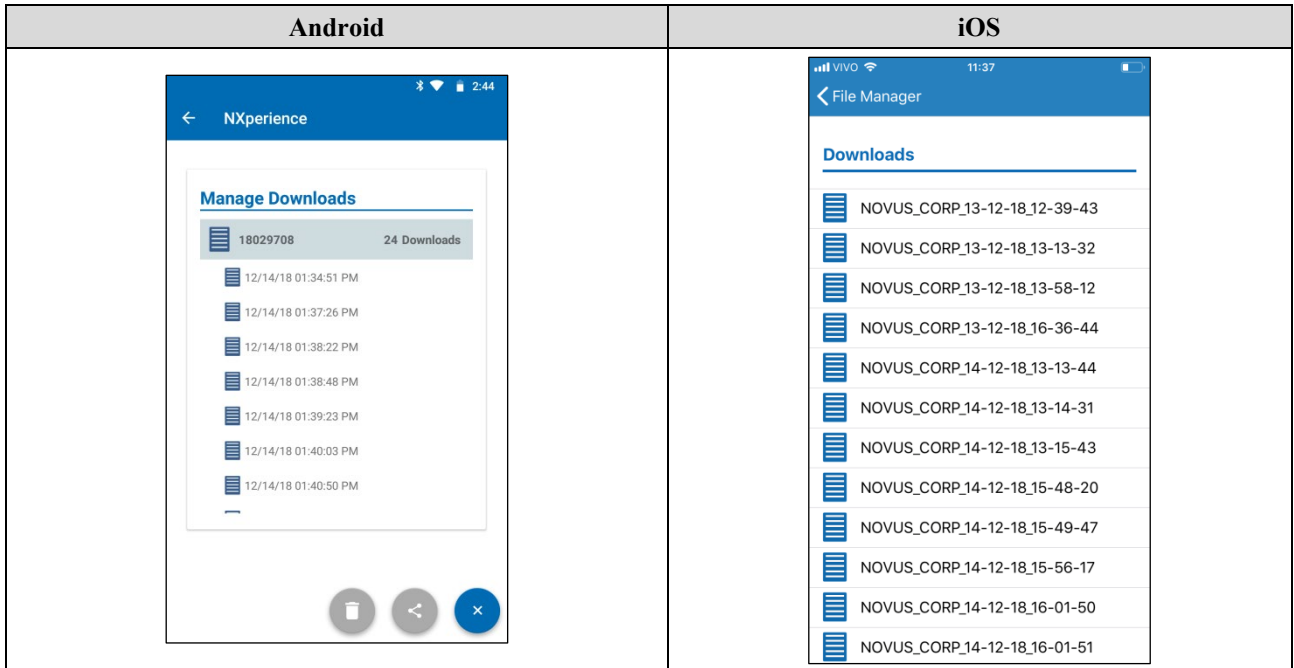





Figure 19 – Downloaded files

For the Android application, once a downloaded data is selected, the button  will change to . For the iOS application, pressing the desired downloaded data and dragging the finger to the left will display the icon . By clicking on it, you can expand the sharing option.

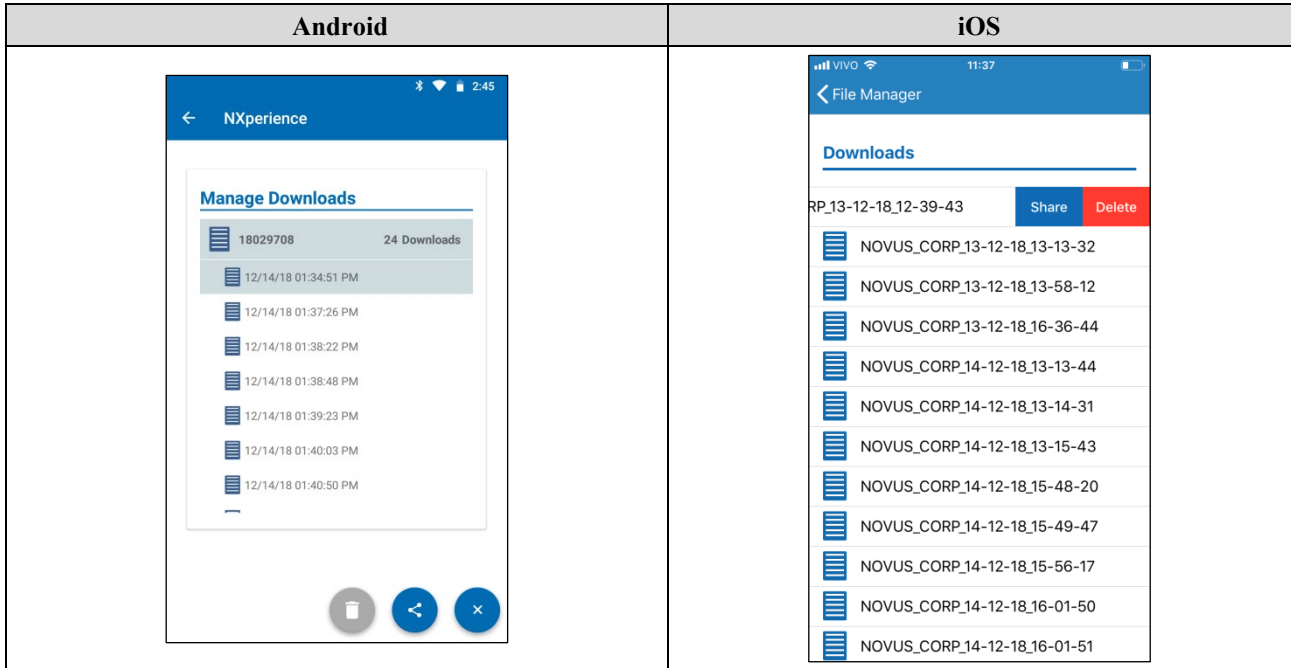



Figure 20 – Data selection

Pressing the  button or the  button will expand the sharing option, allowing you to select by which method you want to share the selected data.

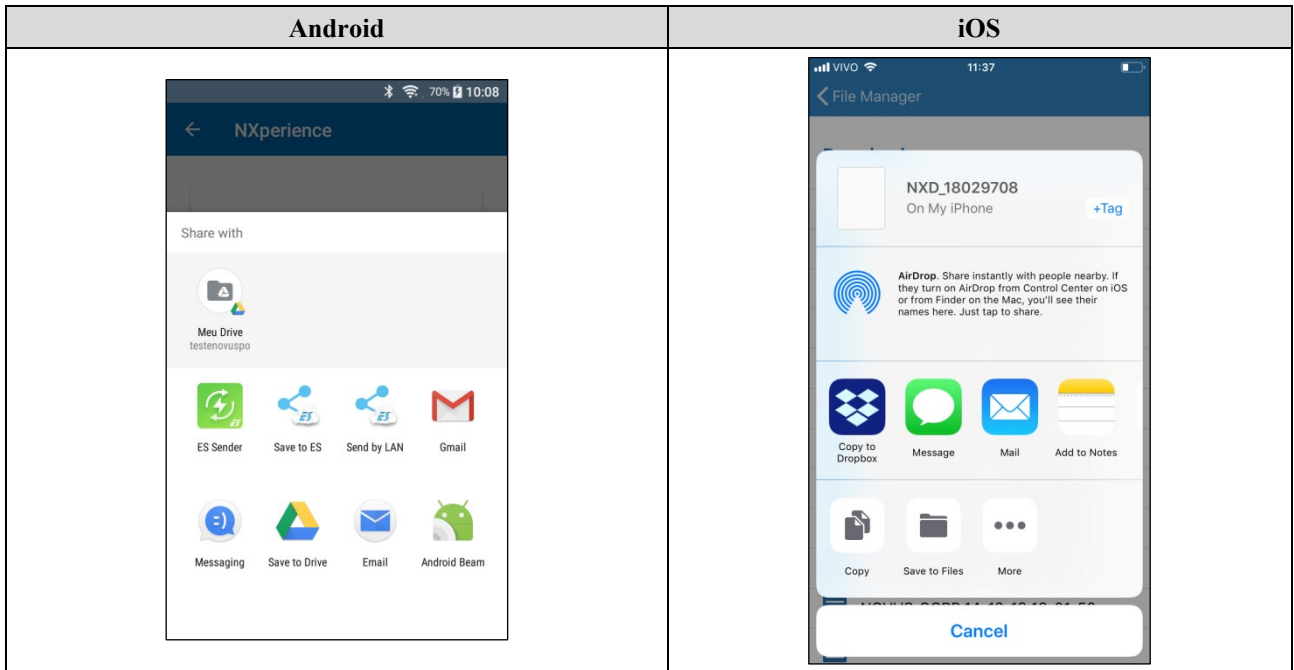



Figure 21 – Sharing data

For the Android application, to delete the selected item from the list, simply press and hold (long click) to open a *checkbox* to select the downloaded file you want to delete. Once this is done, simply press the

 button to delete the selected data.

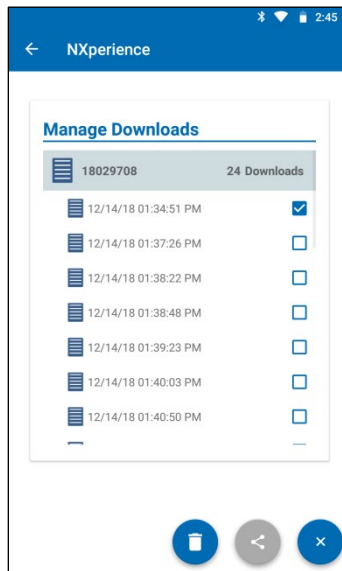

Figure 22 – Manage downloads

For the Android application, to delete all device data, you must press the serial number of the device whose data you want to delete from your smartphone memory and wait for the delete confirmation dialog box to appear.

For the iOS application, simply click on the serial number of the device whose data you wish to delete from your smartphone's memory and drag the data to the left. This move will display the **Delete** button, which will allow you to delete the selected download.

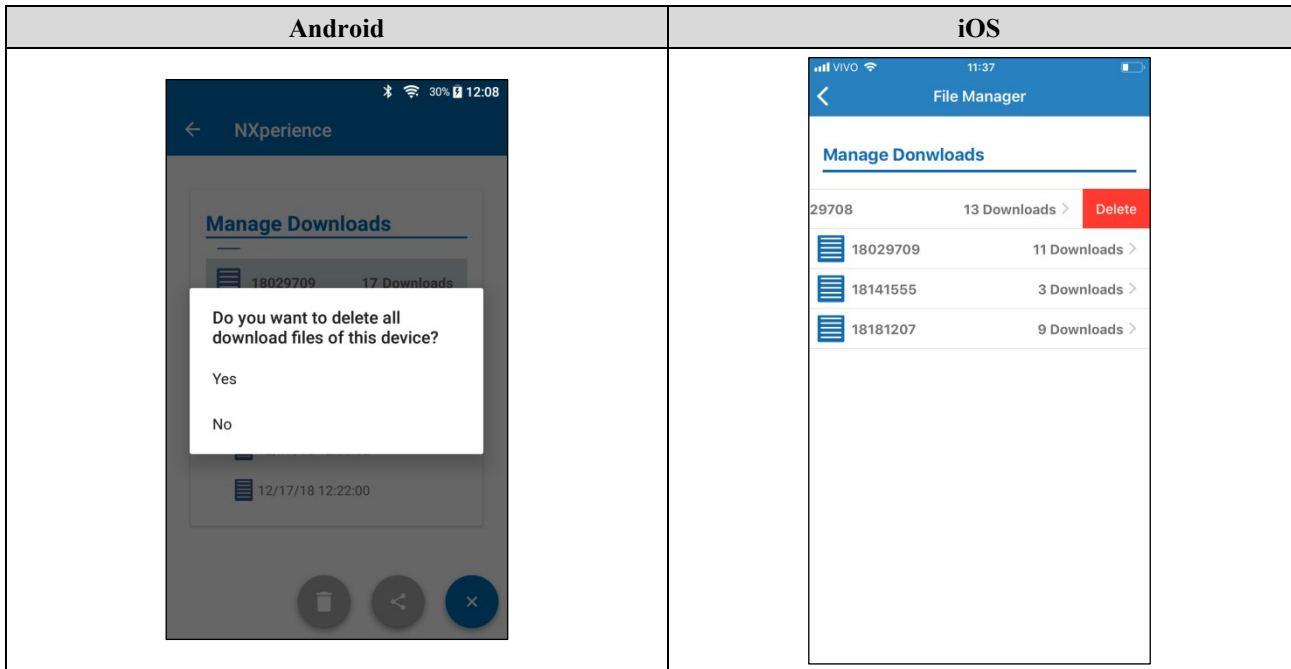

Figure 23 – Delete confirmation

## APPENDIX E - CERTIFICATIONS

### FCC

Contains FCC ID: N7NHL8549G

This device has been tested and found to comply with the limits for a Class A digital device, pursuant to Part 15 of the FCC Rules. These limits are designed to provide reasonable protection against harmful interference when the device is operated in a commercial environment. This device generates, uses, and can radiate radio frequency energy and, if not installed and used in accordance with the instruction manual, it may cause harmful interference to radio communications.

Any changes or modifications not expressly approved by the party responsible for compliance could void the user's authority to operate this device.

RF Exposure: To satisfy FCC RF exposure requirements, a separation distance of 20 cm or more should be maintained between the antenna of this device and persons during operation. To ensure compliance, operations at closer distances than this are not recommended. This device and its antenna(s) must not be co-located or operating in conjunction with any other antenna or transmitter.

This device complies with part 15 of the FCC Rules. Operation is subject to the following two conditions: (1) This device may not cause harmful interference, and (2) this device must accept any interference received, including interference that may cause undesired operation.

### IC

Contains IC: 21571-AVTEG001

This device complies with Industry Canada's license exempt RSS standard(s). Operation is subject to the following two conditions: (1) This device may not cause interference, and (2) This device must accept any interference, including interference that may cause undesired operation of the device.

The installation of the transmitter must ensure that the antenna has a separation distance of at least 20 cm from all persons or compliance must be demonstrated according to the ISED SAR procedure.

Under Industry Canada regulations, this radio transmitter may only operate using an antenna of a type and maximum (or lesser) gain approved for the transmitter by Industry Canada. To reduce potential radio interference to other users, the antenna type and its gain should be so chosen that the equivalent isotropically radiated power (EIRP) is not more than that necessary for successful communication.

### CE Mark / UKCA

This is a Class A device. In a domestic environment, it may cause radio interference and require the user to take proper measures.

### ANATEL

This device is homologated by ANATEL, in accordance with the procedures regulated by Resolution 242/2000, and meets the technical requirements applied.

This equipment is not subject to the protection from harmful interference and may not cause interference with duly authorized systems.

For more information, see the ANATEL website: [www.gov.br/anatel/pt-br](http://www.gov.br/anatel/pt-br).

### NORM CISPR 22

This product is not suitable for use in domestic environments as it may cause electromagnetic interference. Otherwise, the user will be required to take whatever measures are necessary to minimize such electromagnetic interference.

## APPENDIX F - WARRANTY

CAS Dataloggers LLC., warrants the instruments it manufactures against defects in either the materials or the workmanship for a period of one year from the date of delivery to the original customer. This warranty is limited to the replacement or repair of such defects, without charge, when the instrument is returned to CAS Dataloggers. This warranty excludes all other warranties, either express or implied, and is limited to a value not exceeding the purchase price of the instrument.

CAS Dataloggers LLC. shall not be liable for any incidental or consequential loss or damages resulting from the use of the instrument, or for damage to the instrument resulting from accident, abuse, improper implementation, lack of reasonable care, or loss of parts.

Where CAS Dataloggers LLC. supplies to the customer equipment or items manufactured by a third party, then the warranty provided by the third party manufacturer remains.