

# Wi-Fi Pro Quick Start Guide

Use this handy guide to help you get started with your new Accsense Wi-Fi Pro. Have questions? Contact us using the information at the bottom

## Connecting Sensors

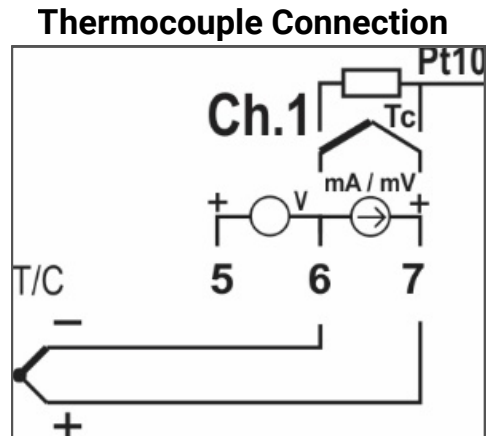
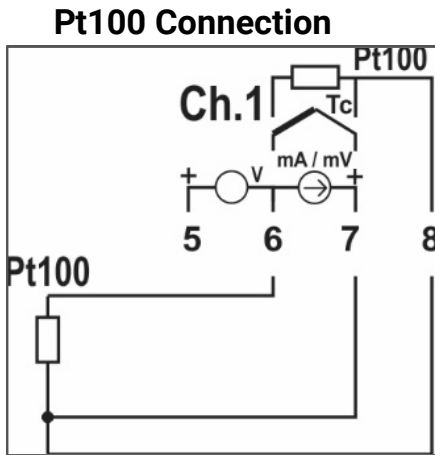

The Accsense Wi-Fi Pro also accepts sensors with voltage or 4-20 mA outputs. Please see the full user guide for information on connecting and configuring these types of sensors.

## Connecting Power

The Wi-Fi Pro is normally powered via the USB connection using the AC adapter and USB cable supplied with the unit. It is also possible to power it using an external 10-30VDC power supply as shown below.

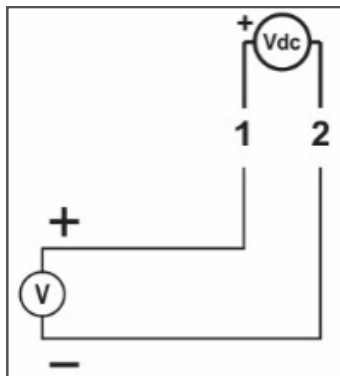

After connection to the power supply, remove the battery tab to enable battery backup power

# Configuring the Logger



Connect the logger to the PC using the USB cable supplied. Download the NXperience software [here](#) or by using the QR code. Then Install and Start it.

## Read Configuration

## Time Zone Configuration

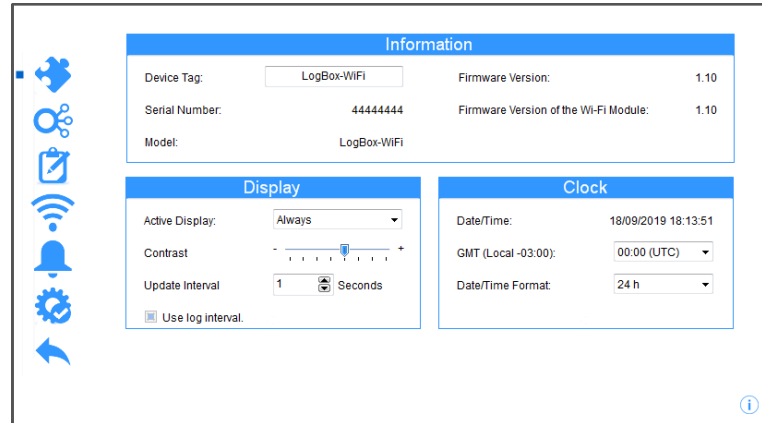
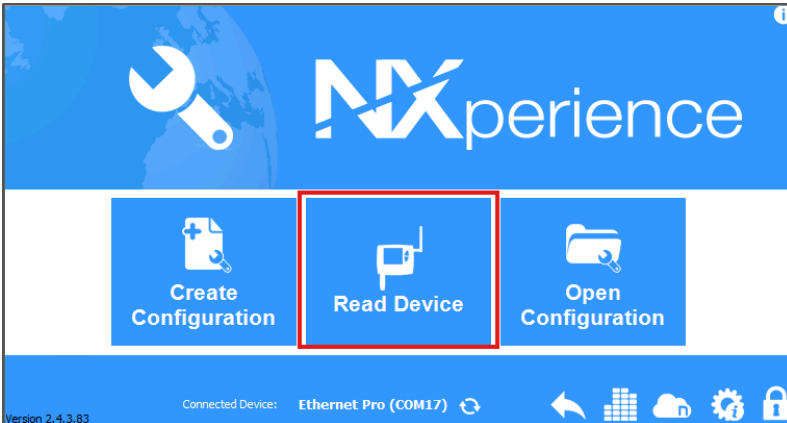

To Start, click “Read Device” to pull in the initial configuration already on the device

Select the correct Time Zone for your location

## Sensor Configuration

## Configure Logging Interval

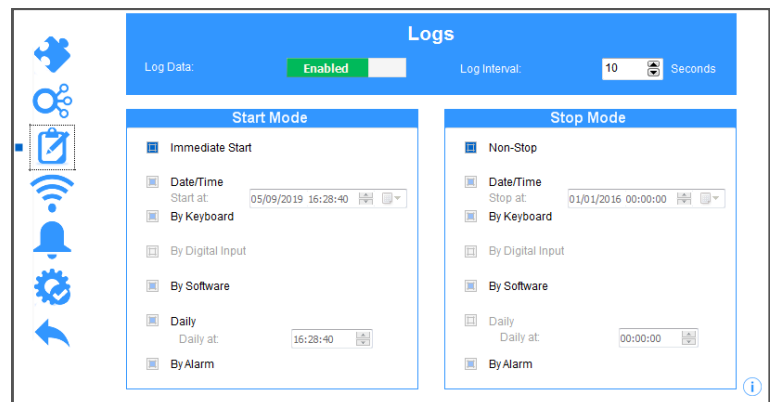
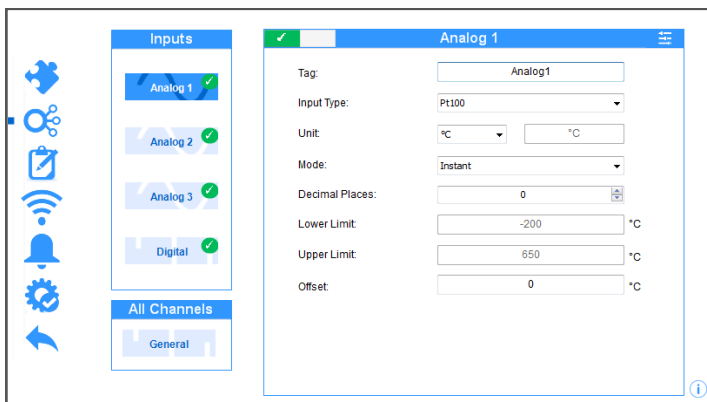

Select the correct sensor(s) for each channel. For the E1-21 RTD, use the PT100 sensor type. For the E1-25 thermocouple, use the type T thermocouple type.

Set the log rate to the time interval you want to upload data. We recommend 15 - 30 minutes as the typical upload interval for most applications.

## Wi-Fi Configuration

Wi-Fi ModBus-TCP MQTT NOVUS Cloud SMTP

Enable Wi-Fi:  Enabled

Access Point SSID: WIFI\_ST\_TESTES

Access Point Password: .....

Obtaining Address: DHCP

IP Address: 10 . 51 . 1 . 106

Subnet Mask: 255 . 255 . 0 . 0

Gateway Default: 10 . 51 . 1 . 254

DNS Server: 10 . 51 . 1 . 9

Configure the Wi-Fi network setting for the SSID and password. When the settings are complete, click the arrow to upload the setting to the logger. After the upload is complete, the logger should start displaying current values within a few minutes.

## Display Reference

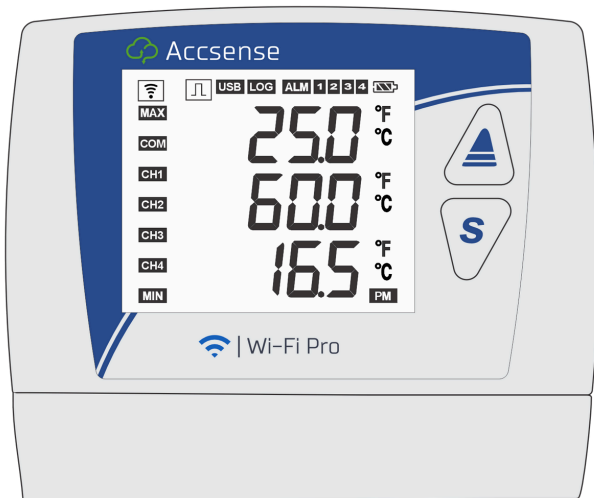

Indicates Wi-Fi is active & connected



Indicates logger is recording



Indicated an alarm has been triggered



Indicates which channel is in alarm



Indicates battery level

## Sign In To Online Account

Accsense  
by CAS Dataloggers

Sign in

E-mail

Password

[Forgot your password?](#)

Sign in

Sign in to your account at [www.monitor.accsense.com](http://www.monitor.accsense.com) using the credentials emailed to you. You can scan the QR code on the next page for the link.

## Change Device & Sensor Info

Click on **Devices** and then click the pencil icon to change device name and settings.

## Add Users & Update Contact Information

Click on **Users** to switch to the User Configuration page. Click Create User to add a new user. Click the Pencil icon next to an existing user to change their settings.

## View Data & Configure Alarms

Device Name	Sensor Name	History	Alarms	Settings	Alarm Status	Last Value	Last Input	Controls
LogBox_Test1	Vaccine1					22.3 Celsius	05/02/2025 11:19:40 am	
LogBox_Test1	Room Temp					68.3 degF	05/02/2025 11:19:40 am	
LogBox_Test1	RH					40 pct	05/02/2025 11:19:40 am	
LogBox_Test2	Mikes office					6 Celsius	03/20/2025 10:46:48 am	
LogBox_Test2	Brent's Office					23.1 Celsius	03/20/2025 10:46:48 am	

Click on **Sensor Summary** to bring up the devices and sensors with the current values and alarm status. Click the graph icon under history to bring up a chart for the sensor. A **Red Clock** icon under Alarm Status will indicate a sensor currently in alarm state. Click the Pencil icon in the Sensor List to change the sensor name. Click the Clock icon under Alarms to bring up the alarm setting window below

The **Alarms** window will show the alerts currently set for the sensor. Click the Pencil icon to change the Alert Settings. The first screen is used to set the Alarm Trigger, Trigger Point, and Filter. Click the Continue button to select the alarm recipients and type of notification.

## View Audit Log

Click the **Audit Log** button to view a list of Alarms and Notifications.

